

## User's Guide



# ADI-6432R BNC

## Multichannel Audio Digital Interface

**SyncAlign™**

**SyncCheck™**

**Intelligent Clock Control™**

**SteadyClock™**

Hi-Precision 24 Bit / 192 kHz  
64-Channel Bidirectional Format Converter  
MADI - AES-3id Interface  
MIDI embedded in MADI  
RS232 embedded in MADI  
MIDI Remote Control

---

▶	<b>Important Safety Instructions</b> .....	4
---	--	---

▶ **General**

<b>1</b>	<b>Introduction</b> .....	6
<b>2</b>	<b>Package Contents</b> .....	6
<b>3</b>	<b>Brief Description and Characteristics</b> .....	6
<b>4</b>	<b>First Usage - Quick Start</b>	
4.1	Controls and Connectors .....	7
4.2	Quick Start .....	9
<b>5</b>	<b>Accessories</b> .....	10
<b>6</b>	<b>Warranty</b> .....	10
<b>7</b>	<b>Appendix</b> .....	10

▶ **Usage and Operation**

<b>8</b>	<b>Front Panel Controls</b>	
8.1	MADI INPUT .....	14
8.2	MADI OUTPUT .....	14
8.3	AES .....	14
8.4	CLOCK .....	15
8.5	REMOTE .....	15
<b>9</b>	<b>Inputs</b>	
9.1	MADI .....	16
9.2	AES-3id .....	16
<b>10</b>	<b>Outputs</b>	
10.1	MADI .....	17
10.2	AES-3id .....	17
<b>11</b>	<b>Word Clock</b>	
11.1	Word Clock Input and Output .....	18
11.2	Technical Description and Background .....	19
11.3	Cables and Termination .....	20
<b>12</b>	<b>MIDI and RS232</b>	
12.1	Transmission of MIDI .....	21
12.2	Remote Controlling the ADI-6432 .....	21
12.3	Remote Control Software .....	22
12.4	RS232 .....	23
<b>13</b>	<b>Application Examples</b>	
13.1	Digital AES-3id Multicore .....	24
13.2	Digital AES-3id Breakout box .....	24
13.3	MADI to MADI Converter .....	26
13.4	AES Inserter .....	26
13.5	MADI Merger .....	26

---

▶ **Technical Reference**

**14 Technical Specifications**

- 14.1 Inputs ..... 30
- 14.2 Outputs ..... 30
- 14.3 MIDI – RS232 ..... 31
- 14.4 Digital ..... 31
- 14.5 General ..... 31
- 14.6 Firmware ..... 32
- 14.7 Connector Pinout RS232 ..... 32
- 14.8 MADI User Bit Chart ..... 32

**15 Technical Background**

- 15.1 Terminology ..... 33
- 15.2 Lock, SyncCheck and SyncAlign ..... 34
- 15.3 MADI Basics ..... 35
- 15.4 SteadyClock ..... 36

**16 Block Diagram** ..... 37

**17 MIDI Implementation Chart**

- 17.1 Basic SysEx Format ..... 38
- 17.2 Message Types ..... 38
- 17.3 MADI Input State – Redundancy Mode ..... 38
- 17.4 Table ..... 39

---

## Important Safety Instructions



### **ATTENTION! Do not open chassis – risk of electric shock**

The unit has non-isolated live parts inside. No user serviceable parts inside. Refer service to qualified service personnel.



### **Mains**

- The device must be earthed – never use it without proper grounding
- Do not use defective power cords
- Operation of the device is limited to the manual
- Use same type of fuse only



To reduce the risk of fire or electric shock do not expose this device to rain or moisture. Prevent moisture and water from entering the device. Never leave a pot with liquid on top of the device. Do not use this product near water, i. e. swimming pool, bathtub or wet basement. Danger of condensation inside – don't turn on before the device has reached room temperature.



### **Installation**

Surface may become hot during operation – ensure sufficient ventilation. Avoid direct sun light and do not place it near other sources of heat, like radiators or stoves. When mounting in a rack, leave some space between this device and others for ventilation.



Unauthorized servicing/repair voids warranty. Only use accessories specified by the manufacturer.



Read the manual completely. It includes all information necessary to use and operate this device.

---

## User's Guide



# ADI-6432R BNC

### ▶ General

---

## 1. Introduction

With the ADI-6432R BNC you have an incredibly versatile digital interface to your supply. From small project studios to broadcast and television, this *Advanced Digital Interface* is the perfect solution for many tasks.

As a consequent continuation of RME's world-wide successful ADI series, the 6432 also contains elaborate technology and the latest integrated circuits. In a few words: The ADI-6432R BNC is a uniquely powerful and high-quality device, which will excite you even after many years of operation.

## 2. Package Contents

Please check that the package contains each of the following:

- ADI-6432R BNC
- Manual
- Power cord

## 3. Brief Description and Characteristics

The ADI-6432 consists of two digital format converters in reference quality, in a standard 19" box with 2 unit height. The compact device has numerous extraordinary features like Intelligent Clock Control (ICC), SyncCheck, SyncAlign, SteadyClock, MIDI over MAD1, RS232 over MAD1, and remote control via MAD1 and MIDI.

All of the ADI-6432 I/Os support 192 kHz/24 bit. The format conversion between MAD1 and AES/EBU operates in both directions at the same time. LEDs of different colours show the present state of incoming and outgoing signals and of the internal processing in a clear way.

The unique Intelligent Clock Control (ICC) allows for a flexible use with internal clock (44.1 up to 192 kHz), external word clock or the digital input signals. These options are intelligently coupled in a way typical for RME, and easy to apply thanks to a clear and easily understandable display of the Lock and Sync states.

The ADI-6432 transmits both MIDI and RS232 invisibly within the MAD1 data stream, maintaining full compatibility. The unit can also be remote controlled via MIDI.

The ADI-6432R BNC has two separated, simultaneously operating power supplies. It can be connected to two different power sources at the same time, enabling a redundancy mode of the power supply. If one of the internal or external power sources fails the unit continues to work without any interruption.

To activate this mode both IEC receptacles have to be connected to different power sources, and both power supplies have to be switched on at the front of the unit, so that both POWER LEDs light up.

The power consumption of the unit in redundancy mode is increased by only a few Watts, caused by the limited efficiency (internal loss) of each single power supply.

---

## 4. First Usage – Quick Start

### 4.1 Controls and Connectors

The front of the ADI-6432 features nine buttons with 31 LEDs, and an extensive Status Display including 97 more LEDs.

**MADI INPUT** determines the current input for the MADI signal (optical/coaxial). The state of the input signal is shown in the STATE section (ERROR, 64-channel mode and 96k frame format) and also in the big LED display in detail.



**AES INPUT** displays the basic state of the AES input signal: ERROR, Double Speed and Quad Speed. The big LED display, **AES INPUT STATE**, shows the presence of a valid input signal separately for each AES input. RME's exclusive *SyncCheck* indicates via flashing LEDs if one of these inputs is locked, but not synchronous to the chosen clock reference.

**WORD INPUT** displays the basic state of the word clock input signal: ERROR, Double Speed and Quad Speed. Note that these LEDs are only active when word has been chosen as clock reference.

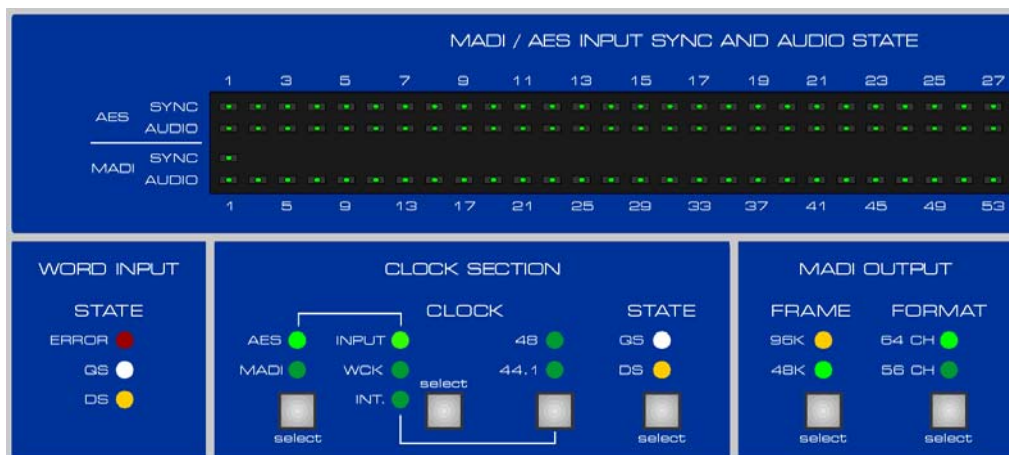

In the **CLOCK SECTION** the current clock reference and frequency multiplier is chosen.

**MADI OUTPUT** is used to configure the MADI output as 56/64 channel or 48k/96k frame format.

**REMOTE** defines the source for MIDI remote control operation (MADI or DIN jack).

**MIDI INPUT** indicates received MIDI data from the 5-pin DIN input or the MADI input.

**COM** indicates serial data being received or transmitted via the COM connector.

**LOCK KEYS** allows to switch off all buttons. This way the ADI-6432 can be secured against accidental operating errors.

---

The rear of the ADI-6432R BNC provides the following connections: 64 BNC connectors (AES-3id I/O), two MADI optical, two MADI coaxial (BNC), two word clock (BNC), two MIDI (5-pin DIN), one RS232 (D-Sub), and two mains power.

**MADI I/O optical:** Standard MADI ports.

**MADI I/O coaxial (BNC):** Standard MADI ports.

**AES-3id (64 x BNC):** Each of the 64 BNC sockets transfers 2 channels of digital audio each.

**WORD IN (BNC):** A push switch allows to activate internal termination (75 Ohms).

**WORD OUT (BNC):** Standard word clock output.

**MIDI I/O (5 pin DIN):** MIDI input and output via 5-pin DIN jacks. Used for transmission of MIDI data via MADI, and for remote control of the ADI-6432.

**COM (9 pin D-sub):** Serial interface for data transmission via MADI.

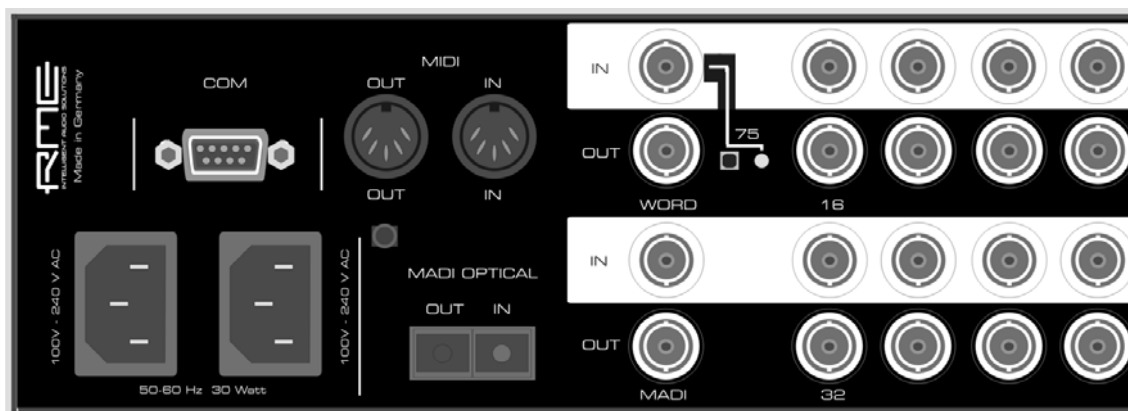

**IEC receptacle** for power connection. The specially developed, internal hi-performance switch mode power supply makes the ADI-6432 operate in the range of 100V to 240V AC. It is short-circuit-proof, has an integrated line-filter, is fully regulated against voltage fluctuations, and suppresses mains interference.

The **ADI-6432R BNC** uses two identical, complete power supplies, which operate simultaneously and in parallel. This allows for a redundant operation on the power side by connecting the second mains receptacle to a different power source. The unit will continue to operate without interruption if one of the power sources fails.



## 4.2 Quick Start

Configuration starts with choosing the MADi input, BNC or optical.

The state of the input signal is displayed by a total of 38 LEDs. Shown are active input, automatic input selection, receiver state, Sync, 56 or 64 channel format, 48k frame or 96k frame, and audio data on a stereo basis. The Sync LED shows the synchronicity between input signal and external/internal clock, or between the active inputs.



In the AES INPUT STATE section, each of the 32 inputs has its own SYNC LED. One LED per (stereo) input indicates audio information within the data stream. An input signal in the range of 60 kHz to 100 kHz will turn the DS LED on. An input signal in the range of 162 kHz to 200 kHz will turn the QS LED on.

The source and frequency of the unit's clock is configured in the CLOCK SECTION. The buttons CLOCK let you step through the options external clock (AES, MADi, word) and internal clock (44.1 or 48 kHz). The button STATE sets the range for the internal, but also the external sample rate. Selecting DS will result in 88.2 and 96 kHz, selecting QS sets 176.4 and 192 kHz.



The MADi output signal can include 56 or 64 channels (FORMAT). The FRAME button switches the MADi output into native Double Speed mode (96K), in case internal or external clock allow this mode to be activated.

The ADI-6432 can be remote controlled by MIDI commands. The button REMOTE is used to select the source of the MIDI remote control commands, and also the destination for the ADI-6432's request replies. The standard MIDI ports or the MADi input and output can be chosen.

LOCK KEYS allows to switch off all buttons. This way the ADI-6432 can be secured against accidental operating errors.

The ADI-6432 remembers all settings before switching off, and sets them automatically when switching on the next time.

---

## 5. Accessories

RME offers several optional components for the ADI-6432, for example MADI Optical Cable:

ONK0100	MADI Optical Network Cable, 1 m (3.3 ft)
ONKD0300	MADI Optical Network Cable, 3 m (9.9 ft)
ONKD0600	MADI Optical Network Cable, 6 m (19.8 ft)
ONKD1000	MADI Optical Network Cable, 10 m (32.8 ft)
ONKD2000	MADI Optical Network Cable, 20 m (65.6 ft)
ONKD5000	MADI Optical Network Cable, 50 m (164 ft)

## 6. Warranty

Each individual ADI-6432R BNC undergoes comprehensive quality control and a complete test at IMM before shipping. The usage of high grade components should guarantee a long and trouble-free operation of the unit.

If you suspect that your product is faulty, please contact your local retailer.

Audio AG grants a limited manufacturer warranty of 6 months from the day of invoice showing the date of sale. The length of the warranty period is different per country. Please contact your local distributor for extended warranty information and service. Note that each country may have regional specific warranty implications.

In any case warranty does not cover damage caused by improper installation or maltreatment - replacement or repair in such cases can only be carried out at the owner's expense.

No warranty service is provided when the product is not returned to the local distributor in the region where the product had been originally shipped.

Audio AG does not accept claims for damages of any kind, especially consequential damage. Liability is limited to the value of the ADI-6432R BNC. The general terms of business drawn up by Audio AG apply at all times.

## 7. Appendix

RME news and further information can be found on our website:

<http://www.rme-audio.com>

Distributor: Audio AG, Am Pfanderling 60, D-85778 Haimhausen, Tel.: (49) 08133 / 91810

Manufacturer:  
IMM Elektronik GmbH, Leipziger Strasse 32, D-09648 Mittweida

### Trademarks

All trademarks and registered trademarks belong to their respective owners. RME, Hammerfall and DIGICheck are registered trademarks of RME Intelligent Audio Solutions. ADI-6432, SteadyClock, SyncAlign, SyncCheck and Intelligent Clock Control (ICC) are trademarks of RME Intelligent Audio Solutions. S/MUX is copyright Sonorus.

Copyright © Matthias Carstens, 04/2011. Version 1.1

---

All entries in this User's Guide have been thoroughly checked, however no guarantee for correctness can be given. RME cannot be held responsible for any misleading or incorrect information provided throughout this manual. Lending or copying any part or the complete manual or its contents as well as the software belonging to it is only possible with the written permission from RME. RME reserves the right to change specifications at any time without notice.

## **CE / FCC Compliance**

### **CE**

This device has been tested and found to comply with the limits of the European Council Directive on the approximation of the laws of the member states relating to electromagnetic compatibility according to RL2004/108/EG, and European Low Voltage Directive RL2006/95/EG.

### **FCC**

This equipment has been tested and found to comply with the limits for a Class B digital device, pursuant to Part 15 of the FCC Rules. These limits are designed to provide reasonable protection against harmful interference in a residential installation. This equipment generates, uses, and can radiate radio frequency energy and, if not installed and used in accordance with the instructions, may cause harmful interference to radio communications. However, there is no guarantee that interference will not occur in a particular installation. If this equipment does cause harmful interference to radio or television reception, which can be determined by turning the equipment off and on, the user is encouraged to try to correct the interference by one or more of the following measures:

- Reorient or relocate the receiving antenna.
- Increase the separation between the equipment and receiver.
- Connect the equipment into an outlet on a circuit different from that to which the receiver is connected.
- Consult the dealer or an experienced radio/TV technician for help.

### **RoHS**

This product has been soldered lead-free and fulfils the requirements of the RoHS directive.

### **ISO 9001**

This product has been manufactured under ISO 9001 quality management. The manufacturer, IMM Elektronik GmbH, is also certified for ISO 14001 (Environment) and ISO 13485 (medical devices).

---

## Note on Disposal

According to the guide line RL2002/96/EG (WEEE – Directive on Waste Electrical and Electronic Equipment), valid for all european countries, this product has to be recycled at the end of its lifetime.

In case a disposal of electronic waste is not possible, the recycling can also be done by IMM Elektronik GmbH, the manufacturer of the ADI-6432.

For this the device has to be sent **free to the door** to:

IMM Elektronik GmbH  
Leipziger Straße 32  
D-09648 Mittweida  
Germany



Shipments not prepaid will be rejected and returned on the original sender's costs.

---

## User's Guide



# ADI-6432R BNC

▶ Usage and Operation

---

## 8. Front panel Controls

### 8.1 MADI INPUT

The button INPUT sets the input to optical or coaxial. The section INPUT STATE helps to avoid errors caused by wrong, missing or not correctly connected inputs, and makes handling the digital MADI format much easier. A total of 38 LEDs display the state of the current input signal.

The SYNC LED lights up as soon as a valid signal is present at the input. An un-synchronous input signal will be signalled by flashing of the SYNC LED. A missing or invalid input signal will cause the ERROR LED to light up.

Audio data present in the input channels is signalled by one AUDIO LED per stereo channel. The green LED is lit as soon as one of the channels of a 2-channel block contains audio data, that is no longer digital zero.

64-channel and 96k frame format are displayed by one LED each. With those LEDs off, the input signal is 56-channel and 48k frame format.

### 8.2 MADI OUTPUT

The buttons FRAME and FORMAT configure the MADI output signal as follows:

FRAME: 48k or 96k frame. 48k frame can be used with Single, Double and Quad Speed. 96k frame is limited to the range 64 kHz to 96 kHz (Double Speed).

FORMAT: 56-channel or 64-channel format.

### 8.3 AES

The INPUT STATE of the 32 inputs is displayed by a total of 67 LEDs.

Each input has its own SYNC LED. If a valid input signal is applied, SyncCheck is active automatically. SyncCheck takes the chosen clock (internal, external, etc.) as reference and compares it with the input clocks. Inputs which are not synchronous will be signalled by flashing of the corresponding SYNC LED.

An AES or SPDIF signal in the range of 60 kHz to 100 kHz will turn the DS (Double Speed) LED on. An AES/EBU or SPDIF signal in the range of 162 kHz to 200 kHz will turn the QS (Quad Speed) LED on.

The AUDIO LEDs light up as soon as the digital signal carries information other than digital zero. The channel doesn't matter. So there is only one channel of audio information necessary for the LED to light up. The amount of level is not indicated.

---

## 8.4 CLOCK

The source and frequency of the unit's clock is configured in the CLOCK SECTION. The buttons CLOCK let you step through the options external clock (AES, MADI, word) and internal clock (44.1 or 48 kHz). The button STATE sets internal, but also the external sample rate to double or quadruple of the basic sample rate.

### **AES, MADI, WCK (Slave Mode)**

Defines the corresponding input as clock reference. A missing or invalid clock source signal is indicated by flashing of the corresponding LED. In case of AES: the input with the lowest number receiving a valid AES signal is used as clock reference.

### **44.1, 48 (Master Mode)**

Activates the internal clock at 44.1 kHz or 48 kHz. Using the button STATE a choice of DS gives 88.2 and 96 kHz, a choice of QS gives 176.4 and 192 kHz respectively.



*With a setting of 44.1 and 48 (internal clock) it is mandatory that the clock rate of the sources is synchronous to the ADI-6432. Therefore the external device has to be synchronized to the ADI-6432's word clock out or MADI/AES out.*

The ADI-6432 thus has to be master, all devices connected to it slave. In order to avoid clicks and drop outs due to faulty or missing synchronicity, a special process called *SyncCheck* compares the incoming data and the ADI-6432's internal clock. The SYNC state is indicated by a flashing (error) or constantly lit (OK) LED.

The button STATE is used to configure the ADI-6432, and with this all of its outputs, to the frequency ranges Single Speed, Double Speed or Quad Speed.

### **No LED (Single Speed)**

All outputs carry a signal in the range of 32 kHz up to 48 kHz.

### **DS (Double Speed)**

AES outputs 1-16 carry a signal in the range of 64 kHz up to 96 kHz. MADI stays at no higher than 48 kHz, with the data transmitted in the S/MUX format. In case MADI OUTPUT has been set to 96k frame, the MADI output also uses 96 kHz.

### **QS (Quad Speed)**

AES outputs 1-8 carry a signal in the range of 176.4 kHz up to 192 kHz. MADI stays at no higher than 48 kHz, with the data transmitted in the S/MUX4 format. Using the 96k frame mode with S/MUX data transmission is not supported.

### **Follow Clock**

In this special mode the ADI-6432 follows the input clock of AES and Word automatically over all three ranges. So at 96 kHz the DS LED automatically lights up, at 192 kHz the QS LED. A manual configuration via the STATE button is no longer required. This function is deactivated for the MADI input, as the sample rate range of the MADI audio data can not be detected automatically.

Activation of Follow Clock: while the firmware version is shown press the CLOCK STATE button. Both LEDs DS/QS light up. Deactivation: same, both LEDs stay dark.

## 8.5 REMOTE

The button REMOTE is used to select the source of the MIDI remote control commands, and also the destination for the ADI-6432's request replies. The standard MIDI ports or the MADI input and output can be chosen.

---

## 9. Inputs

### 9.1 MADI

Both MADI inputs are located on the rear of the ADI-6432.

The BNC input's ground-free design is built according to AES10-1991. The input's impedance is 75 Ohm. It will operate without error from about 180 mVpp.

The optical input uses a FDDI (ISO/IEC 9413-3) compatible optical module, according to AES10-1991. More information can be found in chapter 15.4, MADI Basics.

The ADI-6432 includes automatic input selection. In case the current input signal fails, the unit switches to the other input immediately. This mode, called redundancy mode, offers improved safety against errors on the transmission line. Switching the inputs is done in about one second. The ADI-6432 displays redundancy operation by a blinking LED of the original input, while the input LED of the currently active input will be lit constantly.

### 9.2 AES-3id

The 32 AES-3id inputs are provided on the rear of the ADI-6432R BNC via eight 32 BNC connectors. Every input is transformer-coupled but not ground-free. The BNC sockets are connected to the housing (GND). Channel status and copy protection are being ignored.

The inputs can be used in any combination, e. g. it is sufficient to connect an input signal only to input 3. In slave mode, this input is automatically being used as clock source. If more than one signal is present, the one furthest left is being used as clock source, i. e. the active input with the lowest number.

The ADI-6432 supports single wire only, in the range of 32 kHz up to 192 kHz: a total of 64 channels, 2 channels per AES wire. The effective sample frequency equals the clock on the AES wire. In case a conversion from/to Single, Double and Quad Wire is required, the ADI-192 DD, an 8-channel universal sample rate and format converter, is highly recommended.

Note: In Double Speed mode only inputs 1-16 (channel 1-32) are operational, in Quad Speed mode inputs 1-8 (channel 1-16).

#### Emphasis

AES/EBU and SPDIF can contain an Emphasis information. Audio signals with Emphasis have a strong high frequency boost and thus require a high frequency attenuation on playback.



*An Emphasis indication gets lost! This information is neither passed on to the MADI output, nor to any of the AES outputs!*



---

## 10. Outputs

### 10.1 MADi

At the rear side of the ADI-6432 there are two MADi outputs. The BNC output is built according to AES10-1991. The output's impedance is 75 Ohm. The output voltage will be 600 mVpp when terminated with 75 Ohm.

The optical output uses a FDDI (ISO/IEC 9413-3) compatible optical module, according to AES10-1991. More information can be found in chapter 15.4, MADi Basics.

Basically the MADi signal includes up to 64 channels in AES format, and therefore also the according number of Channel Status data. For the ADI-6432's output these are predefined. Instead of the predefined data it is also possible to output the ones of the AES input channels. The **AES Transparent Mode** uses the Channel Status data of the uneven AES input channels for the corresponding left and right MADi output channel. The data of the right input channels are ignored. The User bits are passed-through unchanged. More details can be found in chapter 10.2.

### 10.2 AES-3id

The 32 AES-3id outputs are provided on the rear of the ADI-6432R BNC via 32 BNC connectors. Every output is transformer-coupled but not ground-free. The BNC sockets are connected to the housing (GND). The output's channel status coding has been implemented according to AES3-1992 Amendment 4:

- 32 kHz, 44.1 kHz, 48 kHz, 64 kHz, 88.2 kHz, 96 kHz, 176.4 kHz, 192 kHz according to the current sample rate
- Audio use, No Copyright, Copy permitted, Format Professional
- Category General, Generation not indicated
- 2-Channel, No Emphasis
- Aux Bits Audio use, 24 Bit
- Origin: 6432

Instead of this predefined coding it is also possible to output the data of the MADi input channels. The **AES Transparent Mode** uses the Channel Status Data of the uneven MADi input channels for the corresponding AES stereo output. The data of the right input channels are ignored. The User bits are passed-through unchanged.

Note: In this mode the function *MIDI/Serial/Remote via MADi* is deactivated. The device can still be remote controlled via the DIN jacks.

Activation of the AES Transparent mode: during power-on press and hold the button CLOCK AES – the CLOCK AES LED lights up. Deactivation: during power-on press and hold the button REMOTE – the REMOTE DIN LED lights up.

The currently active mode is shown during display of the firmware version (after switching on the unit) by the LEDs mentioned above.

---

## 11. Word Clock

### 11.1 Word Clock Input and Output

*SteadyClock* guarantees an excellent performance in all clock modes. Its highly efficient jitter suppression refreshes and cleans up any clock signal, and provides it as reference clock at the BNC output (see section 14.5).

#### Input

The ADI-6432's word clock input is active when WCK is chosen in the clock section. The signal at the BNC input can be Single, Double or Quad Speed, the ADI-6432 automatically adapts to it. As soon as a valid signal is detected, the WCK LED is constantly lit, otherwise it is flashing.

Thanks to RME's *Signal Adaptation Circuit*, the word clock input still works correctly even with heavily mis-shaped, dc-prone, too small or overshoot-prone signals. Thanks to automatic signal centering, 300 mV (0.3V) input level are sufficient in principle. An additional hysteresis reduces sensitivity to 1.0 V, so that over- and undershoots and high frequency disturbances don't cause a wrong trigger.

The ADI-6432's word clock input is shipped as high impedance type (not terminated). A push switch allows to activate internal termination (75 Ohms). The switch is found on the back beside the BNC jacks. Use a small pencil or similar and carefully push the blue switch so that it snaps into its lock position. Another push will release it again and de-activate the termination.

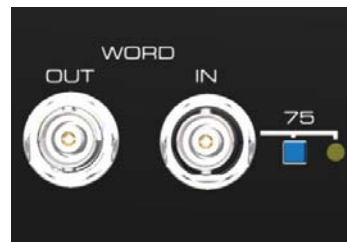

#### Output

The word clock output is constantly active, providing the current sample frequency as word clock signal. In master mode, the word clock will be fixed to 44.1 kHz or 48 kHz (DS x 2, QS x 4). In any other case the sample rate is identical to the one present at the currently chosen clock input. When the current word clock source fails, the last valid sample rate will be held automatically.

The word clock signal received by the ADI-6432 can be distributed to other devices by using the word clock output. With this the usual T-adaptor can be avoided, and the ADI-6432I operates as *Signal Refresher*. This kind of operation is highly recommended, because

- Input and output are phase-locked and in phase (0°) to each other
- *SteadyClock* removes nearly all jitter from the input signal
- the exceptional input (1 Vpp sensitivity instead of the usual 2.5 Vpp, dc cut, *Signal Adaptation Circuit*) plus *SteadyClock* guarantee a secure function also with most critical word clock signals.

Thanks to a low impedance, but short circuit proof output, the ADI-6432 delivers 4 Vpp to 75 Ohms. For wrong termination with 2 x 75 Ohms (37.5 Ohms), there are still 3.3 Vpp at the output.

---

## 11.2 Operation and Technical Background

In the analog domain one can connect any device to another device, synchronization is not necessary. Digital audio is different. It uses a clock, the sample frequency. The signal can only be processed and transmitted when all participating devices share the same clock. If not, the signal will suffer from wrong samples, distortion, crackle sounds and drop outs.

AES/EBU, SPDIF, ADAT and MADI are self-clocking, an additional word clock connection in principle isn't necessary. But when using more than one device simultaneously problems are likely to happen. For example any self-clocking will not work in a loop cabling, when there is no 'master' (main clock) inside the loop. Additionally the clock of all participating devices has to be synchronous. This is often impossible with devices limited to playback, for example CD players, as these have no SPDIF input, thus can't use the self clocking technique as clock reference.

In a digital studio synchronisation is maintained by connecting all devices to a central sync source. For example the mixing desk works as master and sends a reference signal, the word clock, to all other devices. Of course this will only work as long as all other devices are equipped with a word clock or sync input, thus being able to work as slave (some professional CD players indeed have a word clock input). Then all devices get the same clock and will work in every possible combination with each other.



*Remember that a digital system can only have one master! If the ADI-6432's uses its internal clock, all other devices must be set to 'Slave' mode.*

But word clock is not only the 'great problem solver', it also has some disadvantages. The word clock is based on a fraction of the really needed clock. For example SPDIF: 44.1 kHz word clock (a simple square wave signal) has to be multiplied by 256 inside the device using a special PLL (to about 11.2 MHz). This signal then replaces the one from the quartz crystal. Big disadvantage: because of the high multiplication factor the reconstructed clock will have great deviations called jitter. The jitter of a word clock is much higher as when using a quartz based clock.

The end of these problems should have been the so called Superclock, which uses 256 times the word clock frequency. This equals the internal quartz frequency, so no PLL for multiplying is needed and the clock can be used directly. But reality was different, the Superclock proved to be much more critical than word clock. A square wave signal of 11 MHz distributed to several devices - this simply means to fight with high frequency technology. Reflections, cable quality, capacitive loads - at 44.1 kHz these factors may be ignored, at 11 MHz they are the end of the clock network. Additionally it was found that a PLL not only generates jitter, but also rejects disturbances. The slow PLL works like a filter for induced and modulated frequencies above several kHz. As the Superclock is used without any filtering such a kind of jitter and noise suppression is missing.

The actual end of these problems is offered by the **SteadyClock** technology of the ADI-6432. Combining the advantages of modern and fastest digital technology with analog filter techniques, re-gaining a low jitter clock signal of 22 MHz from a slow word clock of 44.1 kHz is no problem anymore. Additionally, jitter on the input signal is highly rejected, so that even in real world usage the re-gained clock signal is of highest quality.

---

### 11.3 Cabling and Termination

Word clock signals are usually distributed in the form of a network, split with BNC T-adapters and terminated with resistors. We recommend using off-the-shelf BNC cables to connect all devices, as this type of cable is used for most computer networks. You will find all the necessary components (T-adapters, terminators, cables) in most electronics and/or computer stores. The latter usually carries 50 Ohm components. The 75 Ohm components used for word clock are part of video technology (RG59).

Ideally, the word clock signal is a 5 Volt square wave with the frequency of the sample rate, of which the harmonics go up to far above 500 kHz. To avoid voltage loss and reflections, both the cable itself and the terminating resistor at the end of the chain should have an impedance of 75 Ohm. If the voltage is too low, synchronization will fail. High frequency reflection effects can cause both jitter and sync failure.

Unfortunately there are still many devices on the market, even newer digital mixing consoles, which are supplied with a word clock output that can only be called unsatisfactory. If the output breaks down to 3 Volts when terminating with 75 Ohms, you have to take into account that a device, of which the input only works from 2.8 Volts and above, does not function correctly already after 3 meter cable length. So it is not astonishing that because of the higher voltage, word clock networks are in some cases more stable and reliable if cables are not terminated at all.

Ideally all outputs of word clock delivering devices are designed as low impedance types, but all word clock inputs as high impedance types, in order to not weaken the signal on the chain. But there are also negative examples, when the 75 Ohms are built into the device and cannot be switched off. In this case the network load is often  $2 \times 75$  Ohms, and the user is forced to buy a special word clock distributor. Note that such a device is generally recommended for larger studios.

The ADI-6432's word clock input can be high-impedance or terminated internally, ensuring maximum flexibility. If termination is necessary (e.g. because ADI-6432 is the last device in the chain), push the switch at the back (see chapter 11.1).

In case the ADI-6432 resides within a chain of devices receiving word clock, plug a T-adapter into its BNC input jack, and the cable supplying the word clock signal to one end of the adapter. Connect the free end to the next device in the chain via a further BNC cable. The last device in the chain should be terminated using another T-adapter and a 75 Ohm resistor (available as short BNC plug). Of course devices with internal termination do not need T-adapter and terminator plug.



*Due to the outstanding SteadyClock technology of the ADI-6432, we recommend not to pass the input signal via T-adapter, but to use the ADI-6432's word clock output instead. Thanks to SteadyClock, the input signal will both be freed from jitter and - in case of loss or drop out – be held at the last valid frequency.*

---

## 12. MIDI and RS232

### 12.1 MIDI Transmission

MADI allows for a transmission of 64 audio channels over long distances with a single line – perfect. But what about MIDI? Be it remote control commands or sequencer data, in practice only a single MADI line will not suffice. Therefore the ADI-6432 also has a MIDI I/O port. The data at the MIDI input are being included into the MADI signal invisibly, and can be collected at the MIDI output of another ADI-6432, ADI-648, Micstasy, ADI-8QS or a HDSP MADI, at the other end of the MADI line.

Technically every single MADI channel includes several additional bits, containing various information (Channel Status). RME use the usually unused *User Bit* of channel 56 (channel 28 in 96k frame mode), to transmit MIDI data invisibly within MADI, ensuring full compatibility.

The block diagram shows the basic MIDI operation. The MIDI input signal is added to the MADI output signal. The MIDI data found in the MADI input signal will be available at the MIDI output. This functionality, a bi-directional MIDI/MADI converter, is always available, and not affected by the REMOTE button.

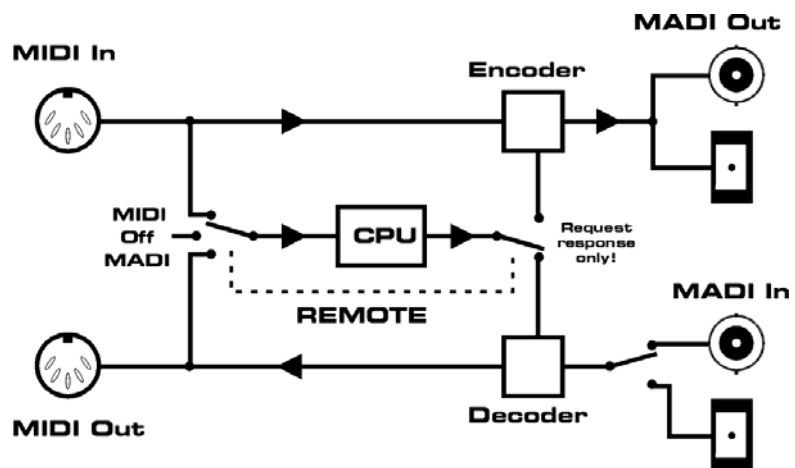

The MIDI input signal will never be transferred directly from MADI to MADI. A MIDI cable connecting MIDI output and MIDI input of the ADI-6432 will realize a direct pass-through of MIDI, from MADI input to MADI output.

### 12.2 Remote Controlling the ADI-6432

The ADI-6432 can be completely remote controlled via MIDI. The CPU shown above reacts on specific commands. Furthermore, upon request the CPU will report the complete device status. This includes all controls and LEDs on the front plate. Each ADI-6432 can be programmed with its own ID, providing a separated remote control of multiple devices via a single MIDI channel. A description of the MIDI implementation is found in chapter 17.

The button REMOTE is used to select the source of the MIDI remote control commands, and also the destination for the ADI-6432's request replies. A push on REMOTE toggles between MIDI port, MADI port and Off. The latter is a safety function to prevent any setup-change by any MIDI signal. In the picture above, the MIDI commands reach the CPU via the MIDI input, and the CPU's feedback on commands is only available at the MIDI output.

To remote control an ADI-6432 from a Hammerfall DSP via MADI, REMOTE has to be set to MADI. As can be seen in the block diagram on the next page, this setup provides a complete data path for MIDI in both directions.

Note: In case the remote control functionality seems not to work the device might be configured for AES Transparent mode, see chapter 10.2.

## 12.3 Remote Control Software

A free remote software for Windows and Mac OS X can be downloaded from the RME website. It can use any existing MIDI port within the system to perform remote control and status requests of any number of supported RME units via a simple mouse click. Most appealing is the combination with a HDSP(e) MADI, offering a direct control of the ADI-6432 via MADI. The remote control software then uses a virtual MIDI port of the card, which directly sends and receives MIDI data via MADI.

Software download: <http://www.rme-audio.de>, Downloads, MIDI Remote

The block diagram shows the signal flow in a MADI remote controlled system. MIDI commands from a software on PC or Mac travel via MADI to the MIDI Out of the ADI-6432. At the same time they reach the 6432's CPU. The MIDI signals of external devices travel via MIDI In and MADI Out back to the software, together with the request responses of the CPU.

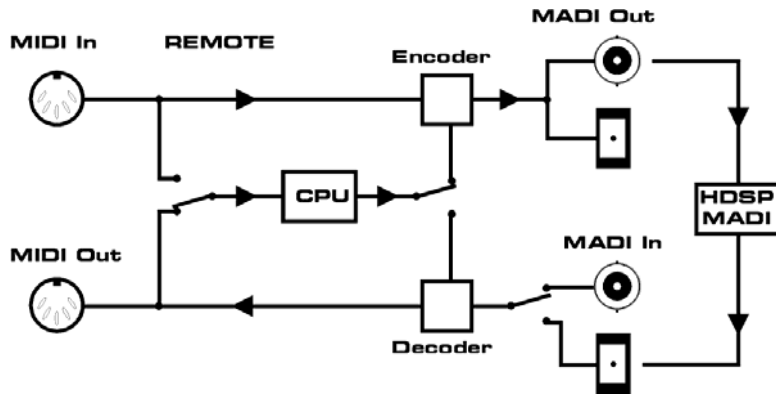

### Brief description of the Windows/Mac OS X Software MIDI Remote

The program includes an extensive english online help (F1). After the start first choose the function **ADI-6432 Front View** in the menu **Functions** (also available via F4). Then select a MIDI input and output via **Options - MIDI I/O Setup**.

Using the command **Options – Start/Stop MIDI I/O** the communication with the ADI-6432 is started. The title bar of the program window shows the current state, like selected ID, online / no response / offline.

**Save Workspace as** allows to store complete setups including all windows in a file, and to reload them at any time.

**Send Single Set of Data** allows an offline configuration of the ADI-6432, and uses a single one-time transmission of all settings.

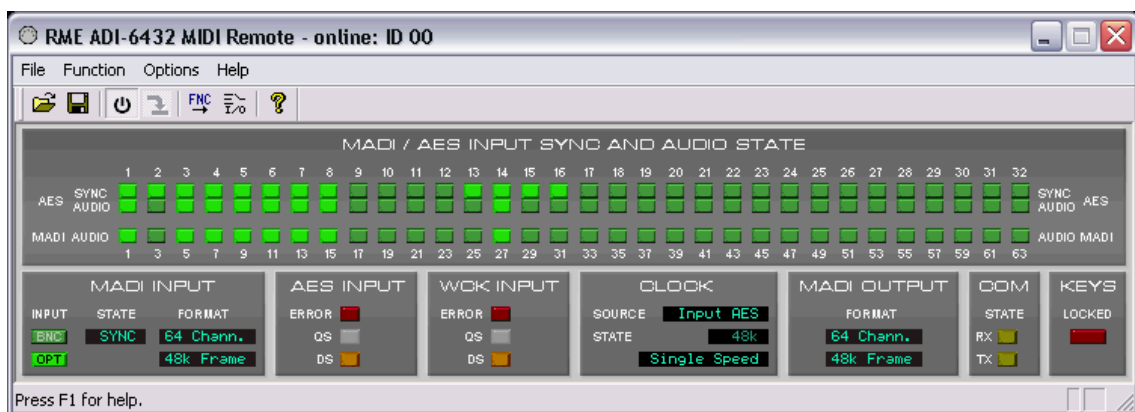

---

## 12.4 RS232

Many devices in the professional range of PA and live sound solutions can be remote controlled using serial communication. The most common standard for those is RS232, the interface known from any computer (COM port). Small and cost-efficient converters between RS232 and newer formats, like RS422 or RS485, are widely spread and therefore easily available.

As already described in the chapter about the technology to transmit MIDI via MADI the ADI-6432 also transmits serial data via user bits, in this case on channels 1 to 9. Supported are the Baud rates 9600, 19200, 38400 and 115200. The configuration is done via MIDI, either by sending the according SysEx string, or more comfortably via the Windows software *MIDI Remote*. The specific setting is stored in the unit and doesn't change on reboot.

### **SysEx Strings**

9600 Bd	F0 00 20 0D 63 7F 20 00 00 F7
19200 Bd	F0 00 20 0D 63 7F 20 00 01 F7
38400 Bd	F0 00 20 0D 63 7F 20 00 03 F7
115200 Bd	F0 00 20 0D 63 7F 20 00 02 F7

Note: In case the transmission of serial data seems not to work the device might be configured for AES Transparent mode, see chapter 10.2.

## 13. Application Examples

### 13.1 Digital AES-3id Multicore

The ADI-6432 is perfectly suited to build up a digital AES multicore. Up to 64 channels can be realized, transmitted via MADI optical cable lossless and undisturbed to places in a distance of up to 2.000 meters.

The amount of the total delay from AES to AES depends on the current sample rate.

32 - 48 kHz	64 - 96 kHz	128 - 192 kHz
4 samples	7 samples	13 samples

4 samples at 48 kHz equal 83  $\mu$ s.

13 samples at 192 kHz equal 68  $\mu$ s.

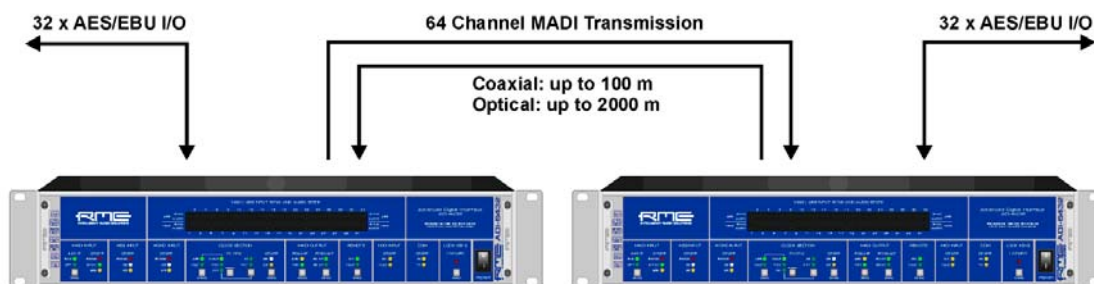

### 13.2 Digital AES-3id Breakout Box

As MADI from/to AES/EBU converter the ADI-6432 is an ideal breakout box for RME's HDSP MADI PCI card. The application breakout box/computer unveils a delay, the so called *offset* between playback and recording. If a signal is played back from the MADI PCI, and recorded again via MADI by performing an AES loopback, the record track will show a specific delay against the playback track. The reason for this is that the HDSP MADI does signal its own offset to the application, but not the ones of externally connected devices – which it can't know anyway.

The following table lists the offset. The values listed here can be entered manually into many programs, thus giving sample-synchronous simultaneous record/playback functionality. At Double Speed and Quad Speed the values rise.

32 - 48 kHz	64 - 96 kHz	128 - 192 kHz
4 samples	7 samples	13 samples

7 samples at 96 kHz equal 73  $\mu$ s.



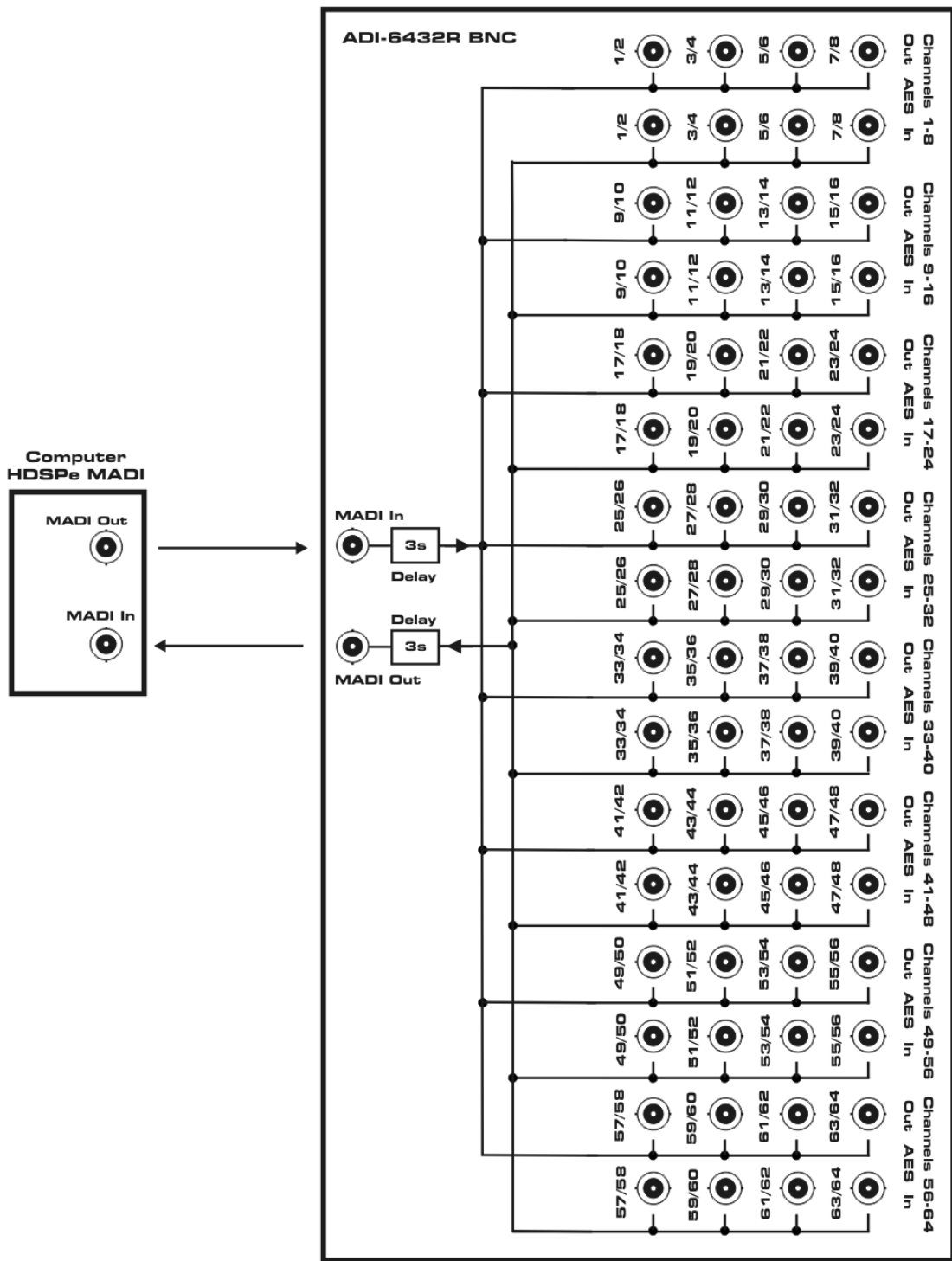

---

### 13.3 MAD I to MAD I Converter

MAD I has been used for quite some time now and therefore not all interfaces from different manufacturers are compatible with each other. An AMS Neve Logic DFC e. g. only accepts the 56 channel input format and when a 64 channel signal is applied, the whole input is muted. There exist lots of other but similar examples.

The ADI-6432 can serve here as a perfect link, because its MAD I input can read any input format. The ADI-6432's MAD I output can be set to 56 channel or 64 channel output mode (see chapter 8.2). After selecting 96K FRAME there are also 28 or 32 channels in a 96k frame mode. With this option, the ADI-6432 can translate a double wire MAD I signal (2 single speed channels contain one double speed channel's data) into a single wire double speed signal (1 channel contains 1 channel's data at double sample rate), or vice-versa.

### 13.4 AES Inserter

An ADI-6432 can be inserted easily into an existing MAD I line. To achieve this simply bridge the according AES I/Os at the breakout cables, i.e. connect XLR male and female. All 64 channels then pass the ADI-6432 unchanged.

Specific AES I/Os can now be used to add new signals, or to loop the existing signals through external devices, thereby processing those signals (for example in effects units). In this application the ADI-6432 serves to insert digital devices into the MAD I data stream, or as adder of additional signals to the not fully utilized MAD I data stream.

**Example:** A mixing desk sends 48 channels via MAD I. 16 more channels from two RME OctaMic-D (8-channel microphone preamp with AES outputs) shall be recorded by a HDSP MAD I into a computer. This application requires one ADI-6432, which has to be inserted into the MAD I line. AES cables are used to pass through channels 1 to 48 from MAD I input to MAD I output. The OctaMic-Ds will be connected to the AES inputs 28 to 32. Now the ADI-6432's MAD I output signal includes both the original MAD I input channels 1 to 48, and the audio signals of the OctaMics (on channels 49 to 56).

### 13.5 MAD I Merger

Another very interesting application becomes reality when using more than one ADI-6432: combining the audio channels of multiple MAD I sources into one single MAD I wire. The need for this application arises quite often, because many devices don't make use of the full channel count. Often only 32 or 40 channels are used. A HDSP MAD I card allows to record 64 channels simultaneously into a computer. To also use the remaining channels, further channels have to be added to the original MAD I signal.

**Example:** The signals of two MAD I devices shall be united to a single MAD I stream. This can be handy, because it requires only one MAD I cable for transmission. It can also be a requirement, because the receiving device may have only one input.

The number of ADI-6432s necessary is identical to the number of MADI signal sources, so it's two for this example. The first ADI-6432 serves as MADI to AES converter. Its AES outputs are connected to the AES inputs of the second ADI-6432. The second ADI-6432 is used as described in the above example, sending the MADI input signal directly to the MADI output. At the same time, the unit fills the unused MADI channels at its MADI output with the audio signals from the AES inputs.

The diagram shows cabling and signal flow of such an application.

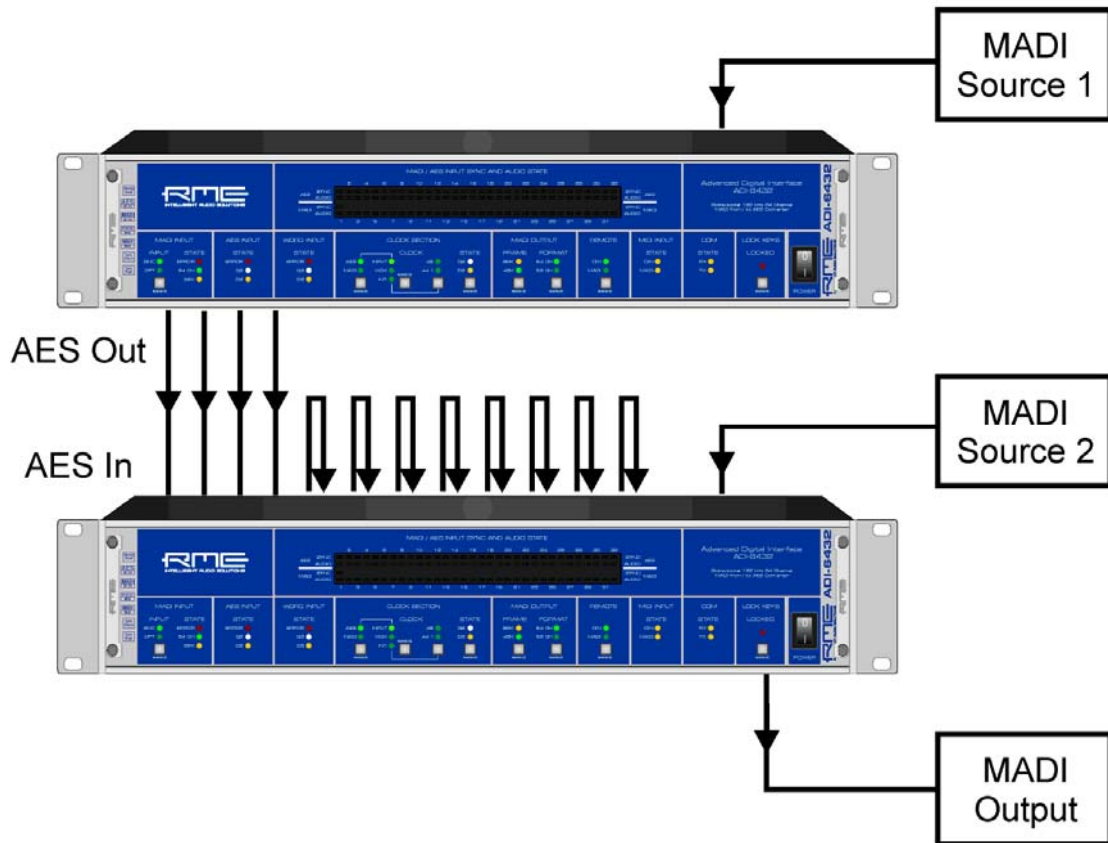



---

## User's Guide



# ADI-6432R BNC

▶ **Technical Reference**

---

## 14. Technical Specifications

### 14.1 Inputs

#### MADI

- Coaxial via BNC, 75 Ohm, according to AES10-1991
- High-sensitivity input stage (< 0.2 Vpp)
- Optical via FDDI duplex SC connector
- 62.5/125 and 50/125 compatible
- Accepts 56 channel and 64 channel mode, and 96k frame
- Single Wire: up to 64 channels 24 bit 48 kHz
- Double Wire: up to 32 channels 24 bit 96 kHz
- Lock range: 28 kHz – 54 kHz
- Jitter when synced to input signal: < 1 ns
- Jitter suppression: > 30 dB (2.4 kHz)

#### AES-3id

- 32 x, transformer-coupled, grounded, according to AES3-4-2009
- High sensitivity input stage (< 0.3 Vpp)
- SPDIF compatible (IEC 60958)
- Accepts Consumer and Professional format, copy protection will be ignored
- Single Wire: 32 x 2 channels 24 bit, up to 192 kHz
- Lock range: 28 kHz - 104 kHz, 162 kHz - 204 kHz
- Jitter when synced to input signal: < 1 ns
- Jitter suppression: > 30 dB (2.4 kHz)

#### Word Clock

- BNC, not terminated (10 kOhm)
- Switch for internal termination 75 Ohm
- Automatic Double/Quad Speed detection and internal conversion to Single Speed
- SteadyClock guarantees super low jitter synchronization even in varispeed operation
- Not affected by DC-offsets within the network
- Signal Adaptation Circuit: signal refresh by auto-center and hysteresis
- Overvoltage protection
- Level range: 1.0 Vpp – 5.6 Vpp
- Lock range: 28 kHz – 220 kHz
- Jitter when synced to input signal: < 1 ns
- Jitter suppression: > 30 dB (2.4 kHz)

### 14.2 Outputs

#### MADI

- Coaxial via BNC, 75 Ohm, according to AES10-1991
- Output voltage 600 mVpp
- Cable length coaxial: up to 100 m
- Optical via FDDI duplex SC connector
- 62.5/125 and 50/125 compatible
- Cable length optical: more than 500 m
- Generates 56 channel and 64 channel mode, and 96k frame
- Single Wire: up to 64 channels 24 bit 48 kHz
- Double Wire / 96k frame: up to 32 channels 24 bit 96 kHz

---

### **AES-3id**

- 32 x, transformer-coupled, grounded, according to AES3-4-2009
- Output voltage Professional 4.5 Vpp
- Format Professional according to AES3-1992 Amendment 4
- Single Wire: 32 x 2 channels 24 bit, up to 192 kHz

### **Word Clock**

- BNC
- Max. output voltage: 5 Vpp
- Output voltage @ 75 Ohm: 4.0 Vpp
- Impedance: 10 Ohm
- Frequency range: 28 kHz – 220 kHz

## **14.3 MIDI - RS232**

### **MIDI**

- 16 channels MIDI
- 5-pin DIN jacks
- Optocoupled, ground-free input
- Invisible transmission via User bit of channel 56 (48k frame)
- Invisible transmission via User bit of channel 28 (96k frame)

### **RS-232**

- 9-pin D-sub
- Invisible transmission via User bit of channels 1 to 9

## **14.4 Digital**

- Clocks: Internal, AES In, MADI In, Word clock In
- Low Jitter Design: < 1 ns in PLL mode, all inputs
- Internal clock: 800 ps Jitter, Random Spread Spectrum
- Jitter suppression of external clocks: > 30 dB (2.4 kHz)
- PLL ensures zero dropout, even at more than 100 ns jitter
- Group delay: typically 3 samples

## **14.5 General**

- Power supply: Double internal switching PSU, 100 - 240 V AC, 2 x 20 Watt
- Typical power consumption: 15 Watts
- Dimensions including rack ears (WxHxD): 483 x 88 x 242 mm (19" x 3.46" x 9.5")
- Dimensions without rack ears/handles (WxHxD): 436 x 88 x 235 mm (17.2" x 3.46" x 9.3")
- Weight: 2 kg ( 4.4 lbs)
- Temperature range: +5° up to +50° Celsius (41° F up to 122°F)
- Relative humidity: < 75%, non condensing

---

## 14.6 Firmware

The ADI-6432's main part has been realized using programmable logic. By re-programming of a little component called Flash-PROM, both function and behaviour of the unit can be changed at any time.

At the time of writing this manual, the unit is shipped with firmware 1.5. The firmware version is displayed after power on for about one second by the SYNC and AUDIO LEDs of the AES INPUT STATE section.

## 14.7 Connector Pinout RS232

The 9-pin D-Sub Connector is wired according to industry standard:

Signal	In (Rx)	Out (Tx)	GND	NC
D-sub	2	3	5	9

Internally connected are pins 1 with 6 and 4, and pin 7 with 8.

## 14.8 MADl User Bit Chart

- RS-232: channels 1 to 9
- ADC: channel 19
- MIDI: channel 56 (48k) / 28 (96k)



---

## 15. Technical Background

### 15.1 Terminology

#### Single Speed

Sample rate range originally used in Digital Audio. Typical applications are 32 kHz (digital radio broadcast), 44.1 kHz (CD), and 48 kHz (DAT).

#### Double Speed

Doubles the original sample rate range, in order to achieve higher audio quality and improved audio processing. 64 kHz is practically never used, 88.2 kHz is quite rare in spite of certain advantages. 96 kHz is a common format. Sometimes called **Double Fast**.

#### Quad Speed

Controversially discussed way of ensuring hi-end audio quality and processing by quadrupling the sample frequency. 128 kHz is non-existent, 176.4 kHz is rare, if at all then 192 kHz is used, e.g. for DVD Audio.

#### Single Wire

Standard audio data transfer, where the audio signal's sample rate is equal to the rate of the digital signal. Used from 32 to 192 kHz. Sometimes called **Single Wide**.

#### Double Wire

Before 1998 there were no receiver/transmitter circuits available that could receive or transmit more than 48 kHz. Higher sample rates were transferred by splitting odd and even bits across the L/R channels of a single AES connection. This provides for twice the data rate, and hence twice the sample rate. A stereo signal subsequently requires two AES/EBU ports.

The Double Wire method is an industry standard today, however it has a number of different names, like **Dual AES**, **Double Wide**, **Dual Line** and **Wide Wire**. The AES3 specification uses the uncommon term *Single channel double sampling frequency mode*. When used with the ADAT format, the term S/MUX is commonly used.

Double Wire not only works with Single Speed signals, but also with Double Speed. As an example, Pro Tools HD, whose AES receiver/transmitter only work up to 96 kHz, uses Double Wire to transmit 192 kHz. Four channels of 96 kHz turn into two channels of 192 kHz.

#### Quad Wire

Similar to Double Wire, with samples of one channel spread across four channels. This way single speed devices can transmit up to 192 kHz, but need two AES/EBU ports to transmit one channel. Also called **Quad AES**.

#### S/MUX

Since the ADAT hardware interface is limited to Single Speed, the Double Wire method is used for sample rates up to 96 kHz, but usually referred to as S/MUX (Sample Multiplexing). An ADAT port supports four channels this way.

#### S/MUX4

The Quad Wire method allows to transmit two channels at up to 192 kHz via ADAT. The method is referred to as S/MUX4.

**Note:** All conversions of the described methods are lossless. The existing samples are just spread or re-united between the channels.

---

## 15.2 Lock, SyncCheck and SyncAlign

Digital signals consist of a carrier and the data. If a digital signal is applied to an input, the receiver has to synchronize to the carrier clock in order to read the data correctly. To achieve this, the receiver uses a PLL (Phase Locked Loop). As soon as the receiver meets the exact frequency of the incoming signal, it is locked. This **Lock** state remains even with small changes of the frequency, because the PLL tracks the receiver's frequency.

If an AES signal is applied to the ADI-6432, the corresponding SYNC LED starts flashing. The unit indicates LOCK, i. e. a valid input signal (in case the signal is also in sync, the LED is constantly lit, see below).

Unfortunately, LOCK does not necessarily mean that the received signal is correct with respect to the clock which processes the read out of the embedded data. Example [1]: The ADI-6432 is set to 44.1 kHz internal clock, and a CD-Player is connected to input AES1. The corresponding LED will start flashing immediately, but the CD-Player's sample rate is generated internally, and thus slightly higher or lower than the ADI-6432's internal sample rate. Result: When reading out the data, there will frequently be read errors that cause clicks and drop outs.

Also when using multiple inputs, a simple LOCK is not sufficient. The above described problem can be solved elegantly by setting the ADI-6432 from internal clock to AES (its internal clock will then be the clock delivered by the CD-Player). But in case a DAT recorder is connected as a second source, there will again be a slight difference in the sample rate, and therefore clicks and drop outs [2].

In order to display those problems optically at the device, the ADI-6432 includes **SyncCheck**. It checks all clocks used for *synchronicity*. If they are not synchronous to each other (i. e. absolutely identical), the SYNC LED of the asynchronous input flashes. In example 1 it would have been obvious that the SYNC AES1 LED kept on flashing after connecting the CD-Player. In example 2, SYNC AES1 would be constantly lit, but the SYNC LED of the input used by the DAT would be flashing.

In practice, SyncCheck allows for a quick overview of the correct configuration of all digital devices. This way one of the most difficult and error-prone topics of the digital studio world finally becomes easy to handle.

A special problem occurs with devices offering several AES or SPDIF inputs. While with MADI all 64 channels share the same clock base, with AES there are several completely independent receivers with their own PLLs and data buffers. Therefore a random error of  $\pm 1$  sample difference between the stereo pairs can occur. The ADI-6432's exclusive **SyncAlign** technology avoids this effect and guarantees sample synchronicity among all four stereo channels.

---

## 15.3 MADl Basics

MADI, the serial **M**ultichannel **A**udio **D**igital Interface, has been defined already in 1989 as an extension of the existing AES3 standard following several manufacturers' wish. The format also known as AES/EBU, a balanced bi-phase signal, is limited to two channels. Simply put, MADI contains 28 of those AES/EBU signals in serial, i. e. after one another, and the sample rate can still even vary by +/-12.5%. The limit which cannot be exceeded is a data rate of 100 Mbit/s.

Because an exact sampling frequency is used in most cases, the 64 channel mode was introduced officially in 2001. It allows for a maximum sample rate of 48 kHz + ca. 1%, corresponding to 32 channels at 96 kHz, without exceeding the maximum data rate of 100 Mbit/s. The effective data rate of the port is 125 Mbit/s due to additional coding.

Older devices understand and generate only the 56 channel format. Newer devices often work in the 64 channel format, but offer still no more than 56 audio channels. The rest is being eaten up by control commands for mixer settings etc. The ADI-6432 shows that this can be done in a much better way, with an invisible transmission of 16 MIDI channels plus serial RS232 data stream, and the 64-channel MADI signal still being 100% compatible.

For the transmission of the MADI signal, proved methods known from network technology were applied. Most people know unbalanced (coaxial) cables with 75 Ohms BNC plugs, they are not expensive and easy to get. The optical interface is much more interesting due to its complete galvanic separation, but for many users it is a mystery, because very few have ever dealt with huge cabinets full of professional network technology. Therefore here are some explanations regarding 'MADI optical'.

- The cables used are standard in computer network technology. They are thus not at all expensive, but unfortunately not available in every computer store.
- The cables have an internal fibre of only 50 or 62.5 µm diameter and a coating of 125 µm. They are called network cables 62.5/125 or 50/125, the former mostly being blue and the latter mostly being orange. Although in many cases not clearly labelled, these are always (!) glass fibre cables. Plastic fibre cables (POF, plastic optical fibre) can not be manufactured in such small diameters.
- The plugs used are also an industry standard and called SC. Please don't mix them up with ST connectors, which look similar to BNC connectors and are being screwed. Plugs used in the past (MIC/R) were unnecessarily big and are not being used any longer.
- The cables are available as a duplex variant (2 cables being glued together) or as a simplex variant (1 cable). The ADI-6432's opto module supports both variants.
- The transmission uses the multimode technique which supports cable lengths of up to almost 2 km. Single mode allows for much longer distances, but it uses a completely different fibre (8 µm). By the way, due to the wave-length of the light being used (1300 nm), the optical signal is invisible to the human eye.

## 15.4 SteadyClock

The SteadyClock technology of the ADI-6432 guarantees an excellent performance in all clock modes. Its highly efficient jitter suppression refreshes and cleans up any clock signal, and provides it as reference clock at the word clock output.

Usually a clock section consists of an analog PLL for external synchronization and several quartz oscillators for internal synchronisation. SteadyClock requires only one quartz, using a frequency not equalling digital audio. Latest circuit designs like hi-speed digital synthesizer, digital PLL, 100 MHz sample rate and analog filtering allow RME to realize a completely newly developed clock technology, right within the FPGA at lowest costs. The clock's performance exceeds even professional expectations. Despite its remarkable features, SteadyClock reacts quite fast compared to other techniques. It locks in fractions of a second to the input signal, follows even extreme varipitch changes with phase accuracy, and locks directly within a range of 28 kHz up to 200 kHz.

SteadyClock has originally been developed to gain a stable and clean clock from the heavily jittery MADI data signal. The embedded MADI clock suffers from about 80 ns jitter, caused by the time resolution of 125 MHz within the format. Common jitter values for other devices are 5 ns, while a very good clock will have less than 2 ns.

The picture to the right shows the MADI input signal with 80 ns of jitter (top graph, yellow). Thanks to SteadyClock this signal turns into a clock with less than 2 ns jitter (lower graph, blue).

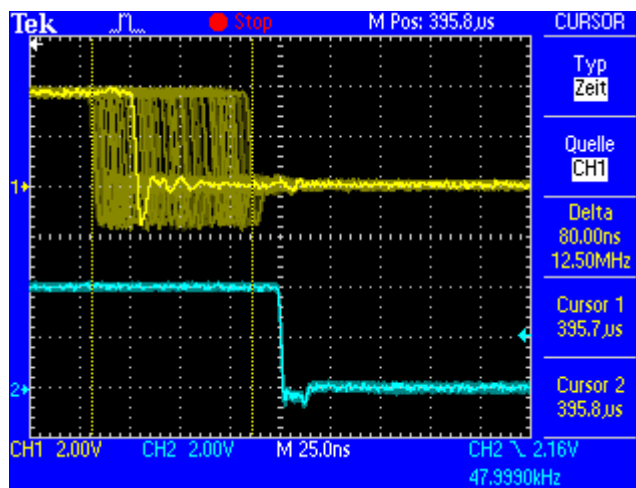

Using the other input sources of the ADI-6432, word clock and AES, you'll most probably never experience such high jitter values. But SteadyClock is not only ready for them, it would handle them just on the fly.

The screenshot to the right shows an extremely jittery word clock signal of about 50 ns jitter (top graph, yellow). Again SteadyClock provides an extreme clean-up. The filtered clock shows less than 2 ns jitter (lower graph, blue).

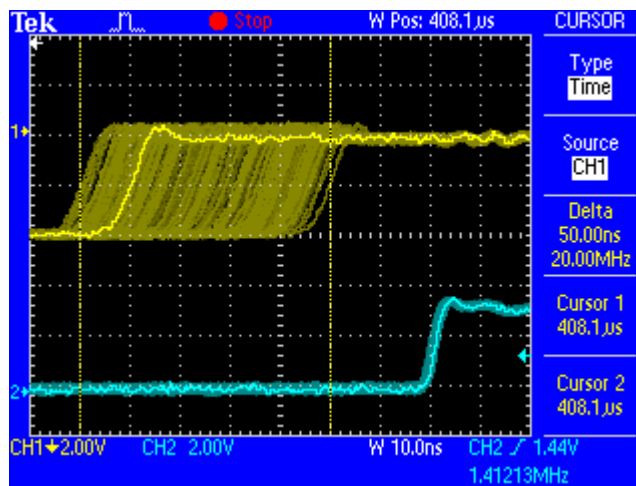

The cleaned and jitter-freed signal can be used as reference clock for any application, without any problem. The signal processed by SteadyClock is of course not only used internally, but also available at the ADI-6432's word clock output. It is also used to clock the digital outputs MADI and AES.

## 16. Block Diagram

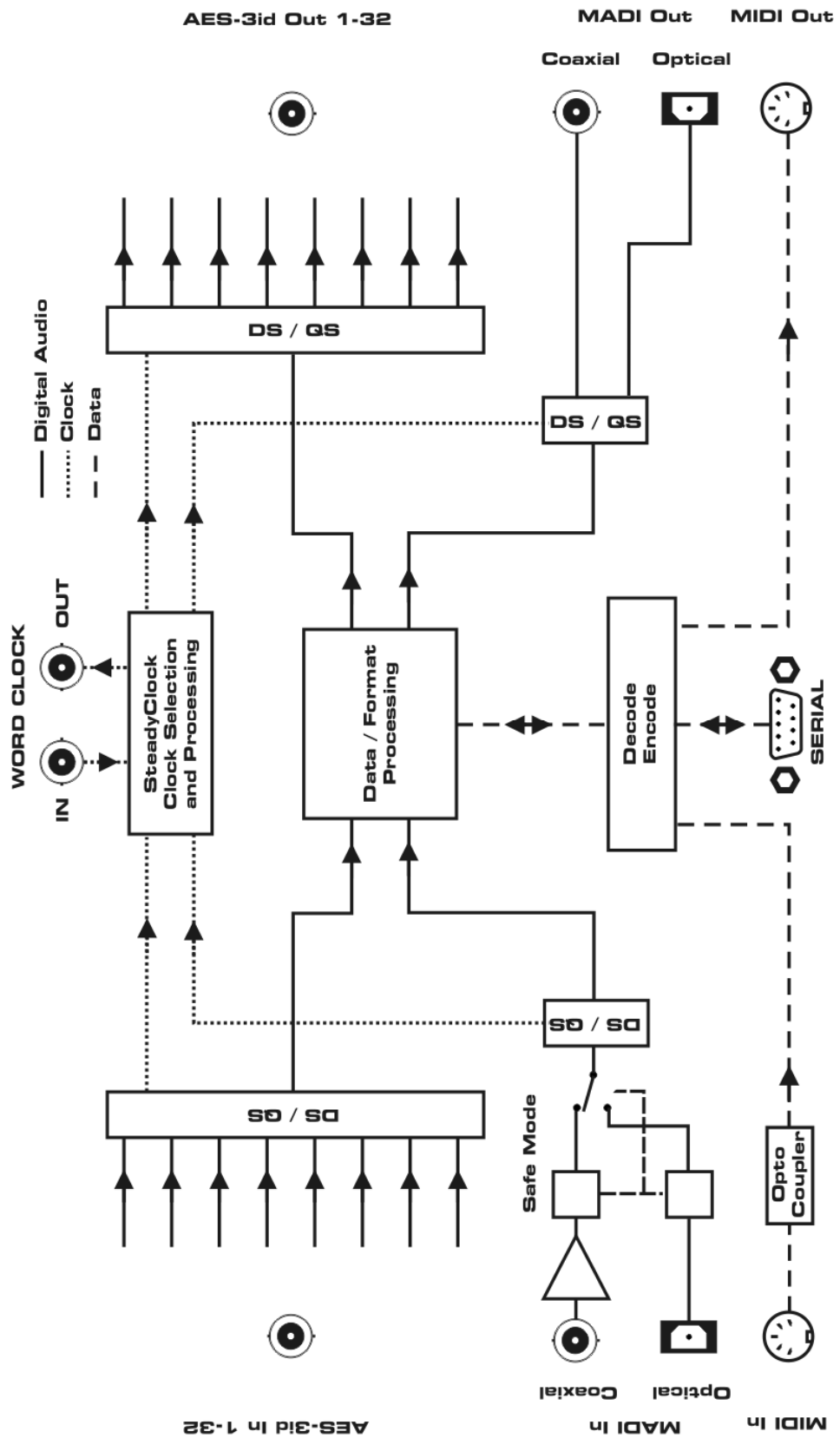

---

## 17. MIDI Implementation Chart ADI-6432

### 17.1 Basic SysEx Format

<u>Value</u>	<u>Name</u>
F0h	SysEx header
00h 20h 0Dh	MIDITEMP manufacturer ID
63h	Model ID (ADI-6432)
00h..7Eh, 7Fh	Device ID. 7Fh = broadcast (all IDs)
mm	Message type
nn	Parameter number (see table 1)
oo	Data byte
F7h	EOX

### 17.2 Message Types

<u>Value</u>	<u>Name</u>
10h	Request value
20h	Set value
30h	Value response

#### Request Value

Format: F0 00 20 0D 63 (dev ID) 10 F7

This string triggers a complete dump of all value response data bytes.

#### Value Response

After being triggered by receiving a request value command, device sends a string of all value response data bytes. Message type is set to 30h.

#### Set Value

Sets any number of parameters.  
nn / oo can be repeated freely.

### 17.3 MADI Input State – Redundancy Mode

The MADI input can be BNC or optical. When the ADI-6432 enters Redundancy mode, it uses the other input, although not chosen and signalled by the MADI input select byte. See below table.

<b>MADI Input Select</b>	<b>MADI Input State</b>	<b>Actual input in use</b>
0 = BNC	0 = normal operation	BNC
1 = Optical	0 = normal operation	Optical
0 = BNC	1 = Redundancy mode	Optical
1 = Optical	1 = Redundancy mode	BNC

## 17.4 Table

No.	No.	Name	Set Value	Value Resp.	Data bytes
00h	0	settings byte 1	x	x	hex coded value of byte (see below)
01h	1	settings byte 2	x	x	hex coded value of byte (see below)
02h	2	info byte 1		x	hex coded value of byte (see below)
03h	3	info byte 2		x	hex coded value of byte (see below)
04h	4	info byte 3		x	hex coded value of byte (see below)
05h	5	MADI audio 1..4		x	bit 0..3 = audio 1..4, bit 4..7 = 0
06h	6	MADI audio 5..8		x	bit 0..3 = audio 5..8, bit 4..7 = 0
07h	7	MADI audio 9..12		x	bit 0..3 = audio 9..12, bit 4..7 = 0
08h	8	MADI audio 13..16		x	bit 0..3 = audio 13..16, bit 4..7 = 0
09h	9	MADI audio 17..20		x	bit 0..3 = audio 17..20, bit 4..7 = 0
0Ah	10	MADI audio 21..24		x	bit 0..3 = audio 21..24, bit 4..7 = 0
0Bh	11	MADI audio 25..28		x	bit 0..3 = audio 25..28, bit 4..7 = 0
0Ch	12	MADI audio 29..32		x	bit 0..3 = audio 29..32, bit 4..7 = 0
0Dh	13	AES lock 1..4		x	bit 0..3 = lock 1..4, bit 4..7 = 0
0Eh	14	AES lock 5..8		x	bit 0..3 = lock 5..8, bit 4..7 = 0
0Fh	15	AES lock 9..12		x	bit 0..3 = lock 9..12, bit 4..7 = 0
10h	16	AES lock 13..16		x	bit 0..3 = lock 13..16, bit 4..7 = 0
11h	17	AES lock 17..20		x	bit 0..3 = lock 17..20, bit 4..7 = 0
12h	18	AES lock 21..24		x	bit 0..3 = lock 21..24, bit 4..7 = 0
13h	19	AES lock 25..28		x	bit 0..3 = lock 25..28, bit 4..7 = 0
14h	20	AES lock 29..32		x	bit 0..3 = lock 29..32, bit 4..7 = 0
15h	21	AES sync 1..4		x	bit 0..3 = sync 1..4, bit 4..7 = 0
16h	22	AES sync 5..8		x	bit 0..3 = sync 5..8, bit 4..7 = 0
17h	23	AES sync 9..12		x	bit 0..3 = sync 9..12, bit 4..7 = 0
18h	24	AES sync 13..16		x	bit 0..3 = sync 13..16, bit 4..7 = 0
19h	25	AES sync 17..20		x	bit 0..3 = sync 17..20, bit 4..7 = 0
1Ah	26	AES sync 21..24		x	bit 0..3 = sync 21..24, bit 4..7 = 0
1Bh	27	AES sync 25..28		x	bit 0..3 = sync 25..28, bit 4..7 = 0
1Ch	28	AES sync 29..32		x	bit 0..3 = sync 29..32, bit 4..7 = 0
1Dh	29	AES audio 1..4		x	bit 0..3 = audio 1..4, bit 4..7 = 0
1Eh	30	AES audio 5..8		x	bit 0..3 = audio 5..8, bit 4..7 = 0
1Fh	31	AES audio 9..12		x	bit 0..3 = audio 9..12, bit 4..7 = 0
20h	32	AES audio 13..16		x	bit 0..3 = audio 13..16, bit 4..7 = 0
21h	33	AES audio 17..20		x	bit 0..3 = audio 17..20, bit 4..7 = 0
22h	34	AES audio 21..24		x	bit 0..3 = audio 21..24, bit 4..7 = 0
23h	35	AES audio 25..28		x	bit 0..3 = audio 25..28, bit 4..7 = 0
24h	36	AES audio 29..32		x	bit 0..3 = audio 29..32, bit 4..7 = 0
25h	37	set device id	x		(request displays in header)

00h	0	settings byte 1	MSB / 7	0
			6	madi input: 0 = BNC, 1 = opt
			5	madi frame: 0 = 48k, 1 = 96k
			4	madi format: 0 = 56ch, 1 = 64ch
			3	0
			2	lock keys: 0 = unlock, 1 = lock
			1 MSB / 1	serial I/O baud rate: 0 = 9600, 1 = 19200
			LSB / 0	serial I/O bd rate: 2 = 115200, 3 = 38400
01h	1	settings byte 2	MSB / 7	0
			6 MSB / 2	clock select: 0 = int 44.1, 1 = int 48, 2 = AES,
			5 1	clock select: 3 = MAD1, 4 = WCK
			4 LSB / 0	clock select
			3	0
			2	0
			1 MSB / 1	clock state: 0 = single speed, 1 = ds, 2 = qs
			LSB / 0	clock state
02h	2	info byte 1	MSB / 7	0
			6	MADI input override
			5	MADI lock
			4	MADI sync
			3	MADI input 96k frame
			2	MADI input 64ch
			1	AES input 192k
			LSB / 0	AES input 96k
03h	3	info byte 2	MSB / 7	0
			6	WCK lock
			5	WCK Input 192k
			4	WCK Input 96k
			3	0
			2	0
			1	0
			LSB / 0	0
04h	4	info byte 3	MSB / 7	0
			6	0
			5	MIDI Input State DIN
			4	MIDI Input State MAD1
			3	COM State RX
			2	COM State TX
			1 MSB / 1	MIDI remote: 0 = off, 1 = DIN, 2 = MAD1
			LSB / 0	MIDI remote