

## User's Guide



# ADI-648

## Multichannel Audio Digital Interface

**SyncAlign<sup>®</sup>**

**SyncCheck<sup>®</sup>**

**Intelligent Clock Control<sup>™</sup>**

**SteadyClock<sup>™</sup>**

Hi-Precision 24 Bit / 192 kHz  
64 Channel MADI / ADAT Converter  
16 x 16 Matrix Router  
MIDI embedded in MADI



**MADI**

24 Bit Interface

Firmware 2.5 or up

---

## Contents

<b>1</b>	<b>Introduction</b> .....	<b>3</b>
<b>2</b>	<b>Package Contents</b> .....	<b>3</b>
<b>3</b>	<b>Brief Description and Characteristics</b> .....	<b>3</b>
<b>4</b>	<b>Technical Specifications</b>	
4.1	Inputs.....	4
4.2	Outputs.....	5
<b>5</b>	<b>First Usage</b>	
5.1	Quick Start .....	6
5.2	Firmware .....	6
5.3	Operating the ADI-648 .....	7
<b>6</b>	<b>The MADi to ADAT Converter</b>	
6.1	General .....	8
6.2	Inputs.....	8
6.3	Input State Display .....	8
6.4	Outputs ADAT Optical.....	9
<b>7</b>	<b>The ADAT to MADi Converter</b>	
7.1	General .....	10
7.2	Inputs.....	10
7.3	Input State Display .....	10
7.4	Outputs MADi.....	11
<b>8</b>	<b>Clock Section</b>	
8.1	Clock Configuration.....	11
8.2	Lock and SyncCheck .....	12
8.3	Word Clock Input and Output.....	13
<b>9</b>	<b>Word Clock</b>	
9.1	Operation and Technical Background .....	14
9.2	Cabling and Termination.....	15
<b>10</b>	<b>MIDI</b>	
10.1	Transmission of MIDI .....	16
10.2	Remote Controlling the ADI-648 .....	16
10.3	Remote Control Software .....	17
<b>11</b>	<b>Special Modes</b>	
11.1	MADi to MADi Converter.....	19
11.2	ADAT Patchbay and Splitter.....	19
11.3	MADi Coaxial/Optical Converter .....	19
11.4	MADi Merger .....	20
11.5	MADiNet.....	20
<b>12</b>	<b>Technical Background</b>	
12.1	DS – Double Speed.....	21
12.2	QS – Quad Speed .....	21
12.3	MADi Basics .....	22
12.4	SteadyClock .....	23
<b>13</b>	<b>Controls and Connectors</b> .....	<b>24</b>
<b>14</b>	<b>Block Diagram</b> .....	<b>25</b>
<b>15</b>	<b>MIDI Implementation Chart</b>	
15.1	Basic SysEx Format .....	26
15.2	Message Types .....	26
15.3	MADi Input State – Redundancy Mode.....	26
<b>16</b>	<b>Warranty</b> .....	<b>29</b>
<b>17</b>	<b>Appendix</b> .....	<b>29</b>

---

## 1. Introduction

With the ADI-648 you have an incredibly versatile digital interface to your supply. What at first looks like a simple MADi to ADAT format converter, turns out to be an extremely flexible problem solver at a closer look. From small project studios to broadcast and television, this *Advanced Digital Interface* is the perfect tool for many tasks.

As a consequent continuation of RME's world-wide successful ADI-8 series, the 648 also contains elaborate technology and the latest integrated circuits. In a few words: The ADI-648 is a uniquely powerful and high-quality device, which will excite you even after many years of operation.

## 2. Package Contents

Please check that your ADI-648 package contains each of the following:

- ADI-648
- Manual
- Power chord

## 3. Brief Description and Characteristics

The ADI-648 consists of two 64-channel digital format converters in reference quality, in a standard 19" box with 1 unit height. The compact device has numerous extraordinary features like Intelligent Clock Control (ICC), SyncCheck<sup>®</sup>, SyncAlign<sup>®</sup>, Bitclock PLL, SteadyClock, patchbay functionality, and a 16x16 Matrix router.

All of the ADI-648 I/Os support 192 kHz/24 bit. As ADAT optical is restricted to 48kHz, in DS mode (Double Speed) two channels are being used for the transmission of one channel's data. The *Sample Split* algorithm used is compatible to *S/MUX* and *Double Wire*, and also implemented in RME's Hammerfall DSP and FireWire devices. Thus the ADI-648 also serves as an ideal MADi frontend for these interfaces, on both Mac and PC.

The format conversion between MADi and ADAT operates in both directions at the same time. LEDs of different colours show the present state of incoming and outgoing signals and of the internal processing in a clear way.

The unique Intelligent Clock Control (ICC) allows for a flexible use with internal clock (44.1, 48, 88.2 and 96 kHz), external word clock or the digital input signals. These options are intelligently coupled in a way typical for RME, and easy to apply thanks to a clear and easily understandable display of the Lock and Sync states.

Futhermore the unique *16 x 16 Matrix Router* allows to use the ADI-648 as patchbay and splitter. All 128 input channels, MADi and ADAT, can be routed to all 128 outputs – even within the same format.

---

## 4. Technical Specifications

- Power supply: Internal switching PSU, 100 - 240 V AC, 20 Watt
- Typical power consumption: 9 Watt
- Dimensions including rack ears (WxHxD): 483 x 44 x 242 mm (19" x 1.73" x 9.5")
- Dimensions without rack ears/handles (WxHxD): 436 x 44 x 235 mm (17.2" x 1.73" x 9.3")
- Weight: 2 kg ( 4.4 lbs)
- Temperature range: +5° up to +50° Celsius (41° F up to 122°F)
- Relative humidity: < 75%, non condensing

### 4.1 Inputs

#### MADI

- Coaxial via BNC, 75 Ohm, according to AES10-1991
- High-sensitivity input stage (< 0.2 Vpp)
  
- Optical via FDDI duplex SC connector
- 62.5/125 and 50/125 compatible
  
- Accepts 56 channel and 64 channel mode, and 96k Frame
- Single Wire: up to 64 channels 24 bit 48 kHz
- Double Wire: up to 32 channels 24 bit 96 kHz
- Quad Wire: up to 16 channels 24 bit 192 kHz
- Lock range: 28 kHz – 54 kHz
- Jitter when synced to input signal: < 1 ns

#### ADAT Optical

- 8 x TOSLINK, according to Alesis specification
- Standard: 64 channels 24 bit, up to 48 kHz
- S/MUX: 8 x 4 channels 24 bit / 96 kHz
- S/MUX4: 8 x 2 channels 24 bit / 192 kHz
- Bitclock PLL ensures perfect synchronisation even in varispeed operation
- Lock range: 31 kHz – 56 kHz
- Jitter when synced to input signal: < 1 ns

#### Word Clock

- BNC, not terminated (10 kOhm)
- Automatic Double Speed detection and internal conversion to Single Speed
- PLL for low jitter synchronisation even in varispeed operation
- Transformer coupled, galvanically isolated input
- Not affected by DC-offsets within the network
- Signal Adaptation Circuit: signal refresh through auto-center and hysteresis
- Overvoltage protection
- Level range: 1.0 Vpp – 5.6 Vpp
- Lock range: 27 kHz – 112 kHz
- Jitter when synced to input signal: < 1 ns
- Switch for internal termination 75 Ohm

---

## **MIDI**

- 16 channels MIDI
- 5-pin DIN jack
- Optocoupled, ground-free input
- Invisible transmission via User bit of channel 56 (up to 48 kHz)
- Invisible transmission via User bit of channel 28 (96k Frame)

## **4.2 Outputs**

### **MADI**

- Coaxial via BNC, 75 Ohm, according to AES10-1991
- Output voltage 600 mVpp
- Cable length: more than 100 m
  
- Optical via FDDI duplex SC connector
- 62.5/125 and 50/125 compatible
- Cable length: more than 500 m
  
- Generates 56 channel and 64 channel mode, and 96k Frame
- Single Wire: up to 64 channels 24 bit 48 kHz
- Double Wire / 96K Frame: up to 32 channels 24 bit 96 kHz
- Quad Wire: up to 16 channels 24 bit 192 kHz

### **ADAT Optical**

- 8 x TOSLINK
- Standard: 8 x 8 channels 24 bit, up to 48 kHz
- S/MUX: 8 x 4 channels 24 bit / 96 kHz
- S/MUX4: 8 x 2 channels 24 bit / 192 kHz

### **Word Clock**

- BNC
- Max. output voltage: 5 Vpp
- Output voltage @ 75 Ohm: 4.0 Vpp
- Impedance: 10 Ohms
- Frequency range: 27 kHz – 56 kHz

## **MIDI**

- 16 channels MIDI
- 5-pin DIN jack

## **4.2 Digital**

- Clocks: Internal, ADAT In, MADI In, Word Clock In
- Low jitter design: < 1 ns in PLL mode, all inputs
- Internal clock: 800 ps jitter, random spread spectrum
- Jitter suppression of external clocks: > 30 dB (2.4 kHz)
- PLL ensures zero dropout, even at more than 100 ns jitter
- Additional Bitclock PLL for trouble-free varispeed ADAT operation
- Supported sample rates: 32 / 44.1 / 48 / 64 / 88.2 / 96 / 176.4 / 192 kHz

---

## 5. First Usage

### 5.1 Quick Start

The user interface of the ADI-648 is characterized by a clearly structured architecture and an unambiguous labelling of the front and rear sides. The device can thus be used easily without a manual, because numerous LEDs show the state of the device and of all incoming and outgoing signals in a strictly logical way. However, we don't want to hold you back from reading this manual, as it includes a lot of important and useful information.

The ADI-648 remembers all settings before switching off and sets them automatically when switching on the next time.

When being switched on for the first time, the ADI-648 comes up in a default mode, which should be appropriate for most applications. The device is in slave mode and gets its reference clock directly out of the MADI input signal. The Matrix Router is deactivated.

A quick guide for operation and functionality of the ADI-648 can be found on the next page.

For transmission of the digital signals into a computer we recommend RME's interface cards of the Hammerfall® DSP series, especially the HDSP MADI. These high quality digital audio cards are available with drivers for all common operating systems, and have the highest reputation world-wide.

### 5.2 Firmware

The ADI-648's main part has been realized using programmable logic. By exchanging a little component called EPROM, both function and behaviour of the unit can be changed at any time.

At the time of writing this manual, the unit is shipped with firmware 2.5. This firmware is not compatible to older units, which do not have the REMOTE key. The firmware version is displayed after power on by the AUDIO LEDs for about one second.

Since firmware version 2.5 not only ADAT input 8, but also the current Matrix configuration influences the output mode. If MADI output group 8 is assigned to any input, the device generates 64 channel format. This is also true when MATRIX STATE is set to OFF. As this channel assignment is factory default, all ADI-648 with firmware 2.5 will generate 64 channel mode as default mode. To activate the 56 channel format for the MADI output, the MADI output group 8 has to be set to Mute, and no signal must be present at ADAT input 8.

### 5.3 Operating the ADI-648

Join us for a small 'tour de ADI', starting on the left side at the *MADI to ADAT Converter*. Configuration starts with choosing the input, BNC or optical. The state of the input signal is displayed by 14 LEDs. Shown are active input, automatic input selection, receiver state, Sync, 56 or 64 channel format, 48k Frame or 96k Frame, and audio data within 8-channel groups. The Sync LED shows the synchronicity between input signal and external/internal clock, or between the active inputs.

The *ADAT to MADI Converter* shows the Sync state for each of the 8 inputs via 8 LEDs. Again 8 LEDs display incoming audio data per 8-channel group.



By using the 96k FRAME key, the MADI output is switched into Double Speed mode. This mode is active when the '96k Frame' LED is lit. In case the WCK LED is lit, the word clock output no longer provides 44.1/48 kHz, but 88.2/96 kHz. However many devices operate in Single Speed only, and distribute – as known from Double Wire – 96 kHz data on two channels. In this case the ADI-648 operates correctly even without changing to 96k Frame mode, because Double Wire will be converted 1:1 to ADAT (S/MUX).

RME's intelligent clock control (ICC) offers extensive and professional means. To start with, the clock source can be set to Internal (crystal), External (BNC word clock) and Input, while Input lets you select between ADAT and MADI. The INT(ernal) clock rates are 44.1 and 48kHz. Lock state is displayed by the state of the input LEDs (flashing or constantly lit).

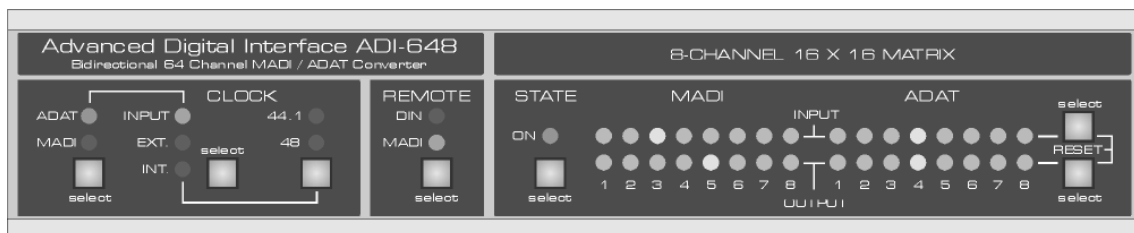

The ADI-648 can be remote controlled by MIDI commands. The key REMOTE is used to select the source of the MIDI commands, and also the destination for the ADI-648's request replies. The normal MIDI ports or the MADI input and output can be chosen. The current REMOTE selection does not have any influence on the basic conversion of MIDI to MADI and vice versa.

Normally all 64 MADI channels will be routed to the according ADAT outputs, and all ADAT inputs to the 64-channel MADI output (optical and coaxial output operate in parallel).

The 16 x 16 Matrix Router can be activated via the STATE key, and allows to change this routing. First choose an output by pressing the Output Select key, then use the Input Select key to select the desired input. An input can be assigned to as many outputs as present (splitting), but an output can not be assigned to more than one input (digital mixing). Routing within the same format is also allowed. This way ADAT inputs can be routed directly to ADAT outputs, without the need of a MADI loopback cabling. So all attached devices can send signals to each other without the need to rearrange the cabling between them.

When stepping through all inputs: the input is muted when no LED is lit. To reset the Matrix Router to the factory default (routing as if de-activated), press the INPUT and OUTPUT SELECT keys at the same time.

---

## 6. The MADI to ADAT Converter

### 6.1 General

This part of the ADI-648 converts MADI to ADAT optical. MADI offers 64 channels of 24 bit audio at up to 48 kHz sample rate, 32 channels at up to 96 kHz, or 16 channels at up to 192 kHz. Transmission happens over a single line, either coaxial (BNC) or fiber optic (network). In both cases the cable length can be more than 100 meters.

The 64 MADI channels are transferred to 8 ADAT optical outputs (TOSLINK). Furthermore, the ADI-648 contains an easy-configurable 8-channel 16x16 **Matrix Router**. Any of the outputs, which are divided into 8-channel blocks, can be fed from any 8-channel input block, both on the ADAT and the MADI side. With this, there is not only free routing within the MADI to ADAT conversion, but also splitting and routing within the same format.

### 6.2 Inputs

Both MADI inputs are located on the rear of the ADI-648.

The BNC input's ground-free design is built according to AES10-1991. The input's impedance is 75 Ohm. It will operate error-free from about 180 mVpp.

The optical input uses a FDDI (ISO/IEC 9413-3) compatible optical module, according to AES10-1991. More information can be found in chapter 12.2, MADI Basics.

The ADI-648 includes automatic input selection. In case the current input signal fails, the unit switches to the other input immediately. This mode, called redundancy mode, offers improved safety against errors on the transmission line. Switching the inputs is done in about one second. The ADI-648 displays redundancy operation by a blinking LED of the original input, while the input LED of the currently active input will be lit constantly.

### 6.3 Input State Display

The state of the MADI input is displayed by different LEDs. The ERROR LED is directly coupled with the MADI-Receiver, and informs the user reliably about the quality of the input signal. The LED will light up red, as soon as there is any error, be it a carrier voltage which is too low, invalid data or any other error which prevents the receiver from accepting the input signal.

If a valid input signal is applied, SyncCheck is active automatically. If the MADI input is not chosen as clock source, SyncCheck takes the chosen clock (Internal, External, ADAT) as reference and compares it with the MADI input clock. In case no synchronous operation is detected the SYNC LED will start blinking.

Audio data present in the input channels is signalled by an AUDIO LED. As the ADI-648 is based on ADAT ports and therefore operates in 8-channel blocks, an AUDIO LED will show audio data from 8 channels simultaneously. The green LED is lit as soon as one of the channels of an 8-channel block contains audio data, that is no longer digital zero.



---

## 6.4 Outputs ADAT Optical

The ADI-648 provides 8 outputs in ADAT optical format. They are fully compatible to all ADAT optical inputs. A usual TOSLINK cable is sufficient for connection.

With the Matrix Router de-activated, all MADl channels are copied to the 8-channel ADAT format in a logical order:

<b>MADI In</b>	<b>1-8</b>	<b>9-16</b>	<b>17-24</b>	<b>25-32</b>	<b>33-40</b>	<b>41-48</b>	<b>49-56</b>	<b>57-64</b>
<b>ADAT Out</b>	<b>1</b>	<b>2</b>	<b>3</b>	<b>4</b>	<b>5</b>	<b>6</b>	<b>7</b>	<b>8</b>

If a MADl signal in Double Wire format (standard frame) is present at the input, technically no special processing is activated, because the output signals will be in Sample Split format (S/MUX) right away.

In 96K FRAME mode, the ADI-648 automatically converts Double Speed data to Sample Split (S/MUX). The data of one MADl channel will be processed and routed to two ADAT channels according to the following table:

<b>MADI In</b>	<b>1</b>	<b>2</b>	<b>3</b>	<b>4</b>	<b>5</b>	<b>6</b>	<b>7</b>	<b>8</b>
<b>DS Signal</b>	<b>1/2</b>	<b>3/4</b>	<b>5/6</b>	<b>7/8</b>	<b>1/2</b>	<b>3/4</b>	<b>5/6</b>	<b>7/8</b>
<b>Port</b>	<b>1</b>	<b>1</b>	<b>1</b>	<b>1</b>	<b>2</b>	<b>2</b>	<b>2</b>	<b>2</b>

<b>MADI In</b>	<b>9</b>	<b>10</b>	<b>11</b>	<b>12</b>	<b>13</b>	<b>14</b>	<b>15</b>	<b>16</b>
<b>DS Signal</b>	<b>1/2</b>	<b>3/4</b>	<b>5/6</b>	<b>7/8</b>	<b>1/2</b>	<b>3/4</b>	<b>5/6</b>	<b>7/8</b>
<b>Port</b>	<b>3</b>	<b>3</b>	<b>3</b>	<b>3</b>	<b>4</b>	<b>4</b>	<b>4</b>	<b>4</b>

<b>MADI In</b>	<b>17</b>	<b>18</b>	<b>19</b>	<b>20</b>	<b>21</b>	<b>22</b>	<b>23</b>	<b>24</b>
<b>DS Signal</b>	<b>1/2</b>	<b>3/4</b>	<b>5/6</b>	<b>7/8</b>	<b>1/2</b>	<b>3/4</b>	<b>5/6</b>	<b>7/8</b>
<b>Port</b>	<b>5</b>	<b>5</b>	<b>5</b>	<b>5</b>	<b>6</b>	<b>6</b>	<b>6</b>	<b>6</b>

<b>MADI In</b>	<b>25</b>	<b>26</b>	<b>27</b>	<b>28</b>	<b>29</b>	<b>30</b>	<b>31</b>	<b>32</b>
<b>DS Signal</b>	<b>1/2</b>	<b>3/4</b>	<b>5/6</b>	<b>7/8</b>	<b>1/2</b>	<b>3/4</b>	<b>5/6</b>	<b>7/8</b>
<b>Port</b>	<b>7</b>	<b>7</b>	<b>7</b>	<b>7</b>	<b>8</b>	<b>8</b>	<b>8</b>	<b>8</b>

As the device internally always operates in Sample Split mode, the Matrix won't change its functionality in Double Wire, Quad Wire (Sample Split = Single Speed) and 96K Frame (Double Speed). In both cases the number of channels is reduced to 28/32 or 14/16. At the same time the Matrix Router no longer operates in 8-channel, but in 4-channel or 2-channel blocks.

---

## 7. The ADAT to MADI Converter

### 7.1 General

This part of the ADI-648 converts ADAT optical to MADI. ADAT optical carries 8 channels of 24 bit audio at up to 48 kHz sample rate, 4 channels at up to 96 kHz, and 2 channels at up to 192 kHz. Transmission is done via a single optical line (TOSLINK). The length of the optical cable is limited to about 10 m.

Because the *Sample Split* (S/MUX, S/MUX4) format doesn't contain a coding, the ADI-648 cannot distinguish it from normal (44.1/48 kHz) material. Whether the MADI output is supposed to work in 96K Frame mode has to be set explicitly by the user.

The inputs can be used in any combination, e. g. it is sufficient to connect an input signal only to input 3. In slave mode, this input is automatically being used as clock source. If more than one signal is present, the one furthest left is being used as clock source, i. e. the active input with the lowest number.

The 8 ADAT optical inputs are transferred to a 64-channel MADI output. Furthermore, the ADI-648 contains an easy-configurable 8-channel 16x16 **Matrix Router**. Any of the outputs, which are divided into 8-channel blocks, can be fed from any 8-channel input block, both on the ADAT and the MADI side. With this, there is not only free routing within the ADAT to MADI conversion, but also splitting and routing within the same format.

### 7.2 Inputs

The ADAT optical inputs of the ADI-648 are fully compatible with all ADAT optical outputs.

ADAT input 8 is used to switch the MADI output format from 56-channel to 64-channel mode. When ADAT input 8 does not receive a valid input signal, the ADI-648 generates a 56-channel MADI signal. When feeding a valid input signal, a 64-channel MADI signal will be generated. This rule is also true when 96K Frame mode is active. Then 28 or 32 channels will be available.

Since firmware version 2.5 the current Matrix configuration also influences the output mode. If MADI output group 8 is assigned to any input, the device generates 64 channel format. This is also true when MATRIX STATE is set to OFF. As this channel assignment is factory default, all ADI-648 will generate 64 channel mode as default mode. To activate the 56 channel format for the MADI output, the MADI output group 8 has to be set to Mute, and no signal must be present at ADAT input 8.

### 7.3 Input State Display

The input state is being displayed by means of 16 LEDs. A missing or invalid input signal is indicated by flashing of the SYNC LED. When using multiple inputs in clock mode ADAT INPUT, the input with the lowest number is being used as clock source. In case ADAT is not chosen as clock reference, SyncCheck takes the chosen clock (internal, external, MADI) as reference and compares it to the clocks of the inputs. Non synchronous inputs will be indicated by flashing of the corresponding SYNC LED. A missing or invalid input signal will be displayed by blinking of the ADAT INPUT CLOCK LED.

Audio data present in the input channels are signalled by a AUDIO LED per input. As the ADI-648 operates in 8-channel blocks, an AUDIO LED will show audio data from 8 channels simultaneously. The green LED is lit as soon as one of the channels of an 8-channel block contains audio data, that is no longer digital zero.

---

## 7.4 Outputs MAD1

At the rear side of the ADI-648 there are two MAD1 outputs.

The BNC output is built according to AES10-1991. The output's impedance is 75 Ohms. The output voltage will be 600 mVpp when terminated with 75 Ohms.

The optical output uses a FDDI (ISO/IEC 9413-3) compatible optical module, according to AES10-1991. More information can be found in chapter 11.2, MAD1 Basics.

With the Matrix Router de-activated, all ADAT channels are copied to the MAD1 format in a logical order:

<b>ADAT In</b>	<b>1</b>	<b>2</b>	<b>3</b>	<b>4</b>	<b>5</b>	<b>6</b>	<b>7</b>	<b>8</b>
<b>MAD1 Out</b>	<b>1-8</b>	<b>9-16</b>	<b>17-24</b>	<b>25-32</b>	<b>33-40</b>	<b>41-48</b>	<b>49-56</b>	<b>57-64</b>

When activating the 96k Frame mode, channel distribution changes as follows:

<b>ADAT In</b>	<b>1</b>	<b>2</b>	<b>3</b>	<b>4</b>	<b>5</b>	<b>6</b>	<b>7</b>	<b>8</b>
<b>MAD1 Out</b>	<b>1-4</b>	<b>5-8</b>	<b>9-12</b>	<b>13-16</b>	<b>17-20</b>	<b>21-24</b>	<b>25-28</b>	<b>29-32</b>

As the device internally always operates in Sample Split mode, the Matrix won't change its functionality in Double Wire, Quad Wire (Sample Split = Single Speed) and 96K Frame (Double Speed). In both cases the number of channels is reduced to 28/32 or 14/16. At the same time the Matrix Router no longer operates in 8-channel, but in 4-channel or 2-channel blocks.

## 8. Clock Section

### 8.1 Clock Configuration

The unique ICC technology (Intelligent Clock Control) allows for a flexible use of both converter units with internal clock (44.1 and 48 kHz, 88.2 and 96 kHz in DS mode), external word clock or the digital input signals. All options are intelligently coupled and easily applicable and understandable, thanks to a clear display of the corresponding lock state.

As clock source, INTERNAL (crystal), EXTERNAL (BNC word clock) and INPUT (the digital input signal ADAT/MAD1) can be chosen. If the clock signal is present, the corresponding LED will light constantly. If no signal is present, the LED will flash.



*The ADI-648 can extract its reference clock directly from the MAD1 signal. In most cases an additional word clock will not be necessary.*

#### INPUT

As displayed on the front panel, the CLOCK SOURCE for the INPUT setting can be the ADAT or MAD1 input. A missing or invalid clock source signal is indicated by flashing of the corresponding LED.

#### EXT.

With EXTERNAL, the ADI-648's word clock input is used as clock reference. The LED will flash, if the word clock is missing or unusable.

---

## INT.

For INTERNAL, 44.1 kHz or 48 kHz sampling rate is available. Note: the key 96k FRAME does only affect the the format of the MADI output, not channel distribution or sample rate of the ADAT outputs.



*For the INTERNAL clock setting it is mandatory that the clock rate of the sources is synchronous to the ADI-648. Therefore the external device has to be synchronized to the ADI-648's word clock out or ADAT/MADI out.*

The ADI-648 thus has to be master, all devices connected to it slave. In order to avoid clicks and drop outs due to faulty or missing synchronicity, a special process called *SyncCheck* compares the incoming data and the ADI-648's internal clock. SYNC is indicated by flashing (error) or constantly lit (OK) LED.

## 8.2 Lock, SyncCheck and SyncAlign

Digital signals consist of a carrier and the data. If a digital signal is applied to an input, the receiver has to synchronize to the carrier clock in order to read the data correctly. To achieve this, the receiver uses a PLL (Phase Locked Loop). As soon as the receiver meets the exact frequency of the incoming signal, it is locked. This **Lock** state remains even with small changes of the frequency, because the PLL tracks the receiver's frequency.

If an ADAT or MADI signal is applied to the ADI-648, the corresponding input LED starts flashing. The ADI-648 indicates LOCK, i. e. a valid input signal (in case the signal is in sync, the LED will be lit constantly, see below).

Unfortunately, LOCK does not necessarily mean that the received signal is correct with respect to the clock which processes the read out of the embedded data. Example [1]: The ADI-648 is set to 44.1 kHz INT(ernal), and a mixing desk having an ADAT output is connected to input ADAT1. The INPUT LED will show LOCK immediately, but the mixing desk's clock is usually gernetaed internally (clock mode master), thus slightly higher or lower than the ADI-648's internal sample rate. Result: When reading out the data, there will frequently be read errors that cause clicks and drop outs.

Also when using multiple inputs, a simple LOCK is not sufficient. The problem described above can be solved elegantly by setting the ADI-648 from INT to INPUT (its internal clock will then be the clock delivered by the mixing desk). But in case another asynchronous source is connected, there will again be a slight difference in the sample rate, and therefore clicks and drop outs.

In order to display those problems optically at the device, the ADI-648 contains **SyncCheck**<sup>®</sup>. It checks all clocks used for synchronicity. If they are not synchronous to each other (i. e. absolutely identical), the SYNC LED of the asynchronous input flashes. If in total sync, the LED will be lit constantly. In example 1 it would have been obvious at once that the SYNC ADAT1 LED was flashing.

In practice, SyncCheck allows for a quick overview of the correct configuration of all digital devices. So one of the most difficult and error-prone topics of the digital studio world finally becomes easy to handle.

---

## 8.3 Word Clock Input and Output

*SteadyClock* guarantees an excellent performance in all clock modes. Its highly efficient jitter suppression refreshes and cleans up any clock signal, and provides it as reference clock at the BNC output (see section 12.4).

### Input

The ADI-648's transformer isolated word clock input is active when EXT is chosen in the clock section. The signal at the BNC input can be single or double speed, the ADI-648 automatically adapts to it. As soon as a valid signal is detected, the EXT LED is constantly lit, otherwise it is flashing.

Thanks to RME's *Signal Adaptation Circuit*, the word clock input still works correctly even with heavily mis-shaped, dc-prone, too small or overshoot-prone signals. Thanks to automatic signal centering, 300 mV (0.3V) input level are sufficient in principle. An additional hysteresis reduces sensitivity to 1.0 V, so that over- and undershoots and high frequency disturbances don't cause a wrong trigger.

The ADI-648's word clock input is shipped as high impedance type (not terminated). A push switch allows to activate internal termination (75 Ohms). The switch is found on the back between the BNC jacks. Use a small pencil or similar and carefully push the blue switch so that it snaps into its lock position. Another push will release it again and de-activate the termination.



### Output

The word clock output is constantly active, providing the current sample frequency as word clock signal. In master mode (Int.), the word clock will be fixed to 44.1 kHz or 48 kHz. In any other case the sample rate is identical to the one present at the currently chosen clock input. When the current word clock source fails, the last valid sample rate will be held automatically.

The word clock signal received by the HDSP MAD1 can be distributed to other devices by using the word clock output. With this the usual T-adaptor can be avoided, and the HDSP MAD1 operates as *Signal Refresher*. This kind of operation is highly recommended, because

- Input and output are phase-locked and in phase (0°) to each other
- *SteadyClock* removes nearly all jitter from the input signal
- the exceptional input (1 Vpp sensitivity instead of the usual 2.5 Vpp, dc cut, *Signal Adaptation Circuit*) plus *SteadyClock* guarantee a secure function also with most critical word clock signals.



*The wordclock output usually operates in Single Speed mode, as do all ADAT and TDIF ports.*

In S/MUX or Double Speed mode, the word clock output will therefore be no higher than 48 kHz. In case a Double Speed word clock is needed (88.2 or 96 kHz), press the key 96K FRAME several times, until the LED WCK is lit.

Thanks to a low impedance, but short circuit proof output, the ADI-648 delivers 4 Vpp to 75 Ohms. For wrong termination with 2 x 75 Ohms (37.5 Ohms), there are still 3.3 Vpp at the output.

---

## 9. Word Clock

### 9.1 Operation and Technical Background

In the analog domain one can connect any device to another device, a synchronization is not necessary. Digital audio is different. It uses a clock, the sample frequency. The signal can only be processed and transmitted when all participating devices share the same clock. If not, the signal will suffer from wrong samples, distortion, crackle sounds and drop outs.

AES/EBU, SPDIF, ADAT and MADI are self-clocking, an additional word clock connection in principle isn't necessary. But when using more than one device simultaneously problems are likely to happen. For example any self-clocking will not work in a loop cabling, when there is no 'master' (main clock) inside the loop. Additionally the clock of all participating devices has to be synchronous. This is often impossible with devices limited to playback, for example CD players, as these have no SPDIF input, thus can't use the self clocking technique as clock reference.

In a digital studio synchronisation is maintained by connecting all devices to a central sync source. For example the mixing desk works as master and sends a reference signal, the word clock, to all other devices. Of course this will only work as long as all other devices are equipped with a word clock or sync input, thus being able to work as slave (some professional CD players indeed have a word clock input). Then all devices get the same clock and will work in every possible combination with each other.



*Remember that a digital system can only have one master! If the ADI-648's clock mode is set to 'Master', all other devices must be set to 'Slave'.*

But word clock is not only the 'great problem solver', it also has some disadvantages. The word clock is based on a fraction of the really needed clock. For example SPDIF: 44.1 kHz word clock (a simple square wave signal) has to be multiplied by 256 inside the device using a special PLL (to about 11.2 MHz). This signal then replaces the one from the quartz crystal. Big disadvantage: because of the high multiplication factor the reconstructed clock will have great deviations called jitter. The jitter of a word clock is much higher as when using a quartz based clock.

The end of these problems should have been the so called Superclock, which uses 256 times the word clock frequency. This equals the internal quartz frequency, so no PLL for multiplying is needed and the clock can be used directly. But reality was different, the Superclock proved to be much more critical than word clock. A square wave signal of 11 MHz distributed to several devices - this simply means to fight with high frequency technology. Reflections, cable quality, capacitive loads - at 44.1 kHz these factors may be ignored, at 11 MHz they are the end of the clock network. Additionally it was found that a PLL not only generates jitter, but also also rejects disturbances. The slow PLL works like a filter for induced and modulated frequencies above several kHz. As the Superclock is used without any filtering such a kind of jitter and noise suppression is missing. No wonder Superclock did not become a commonly accepted standard.

The actual end of these problems is offered by the **SteadyClock** technology of the ADI-648. Combining the advantages of modern and fastest digital technology with analog filter techniques, re-gaining a low jitter clock signal of 22 MHz from a slow word clock of 44.1 kHz is no problem anymore. Additionally, jitter on the input signal is highly rejected, so that even in real world usage the re-gained clock signal is of highest quality.

---

## 9.2 Cabling and Termination

Word clock signals are usually distributed in the form of a network, split with BNC T-adapters and terminated with resistors. We recommend using off-the-shelf BNC cables to connect all devices, as this type of cable is used for most computer networks. You will find all the necessary components (T-adapters, terminators, cables) in most electronics and/or computer stores. The latter usually carries 50 Ohm components. The 75 Ohm components used for word clock are part of video technology (RG59).

Ideally, the word clock signal is a 5 Volt square wave with the frequency of the sample rate, of which the harmonics go up to far above 500 kHz. To avoid voltage loss and reflections, both the cable itself and the terminating resistor at the end of the chain should have an impedance of 75 Ohm. If the voltage is too low, synchronization will fail. High frequency reflection effects can cause both jitter and sync failure.

Unfortunately there are still many devices on the market, even newer digital mixing consoles, which are supplied with a word clock output that can only be called unsatisfactory. If the output breaks down to 3 Volts when terminating with 75 Ohms, you have to take into account that a device, of which the input only works from 2.8 Volts and above, does not function correctly already after 3 meter cable length. So it is not astonishing that because of the higher voltage, word clock networks are in some cases more stable and reliable if cables are not terminated at all.

Ideally all outputs of word clock delivering devices are designed as low impedance types, but all word clock inputs as high impedance types, in order to not weaken the signal on the chain. But there are also negative examples, when the 75 Ohms are built into the device and cannot be switched off. In this case the network load is often 2 x 75 Ohms, and the user is forced to buy a special word clock distributor. Note that such a device is generally recommended for larger studios.

The ADI-648's word clock input can be high-impedance or terminated internally, ensuring maximum flexibility. If termination is necessary (e.g. because ADI-648 is the last device in the chain), push the switch at the back (see chapter 8.3).

In case the ADI-648 resides within a chain of devices receiving word clock, plug a T-adapter into its BNC input jack, and the cable supplying the word clock signal to one end of the adapter. Connect the free end to the next device in the chain via a further BNC cable. The last device in the chain should be terminated using another T-adapter and a 75 Ohm resistor (available as short BNC plug). Of course devices with internal termination do not need T-adaptor and terminator plug.



*Due to the outstanding SteadyClock technology of the ADI-648, we recommend not to pass the input signal via T-adapter, but to use the ADI-648's word clock output instead. Thanks to SteadyClock, the input signal will both be freed from jitter and - in case of loss or drop out - be held at the last valid frequency.*

---

## 10. MIDI

### 10.1 MIDI Transmission

MADI allows for a transmission of 64 audio channels over long distances with a single line – perfect. But what about MIDI? Be it remote control commands or sequencer data, in practice only a single MADI line will not suffice. Therefore the ADI-648 also has a MIDI I/O port. The data at the MIDI input are being included into the MADI signal invisibly, and can be collected at the MIDI output of another ADI-648, or a Hammerfall DSP MADI, at the other end of the MADI line.

Technically every single MADI channel includes several additional bits, containing various information (Channel Status). RME use the usually unused *User Bit* of channel 56 (channel 28 in 96k Frame mode), to transmit MIDI data invisibly within MADI, ensuring full compatibility.

The block diagram shows the basic MIDI operation. The MIDI input signal is added to the MADI output signal. The MIDI data found in the MADI input signal will be available at the MIDI output. This functionality, a bi-directional MIDI/MADI converter, is always available, and not affected by the REMOTE key.

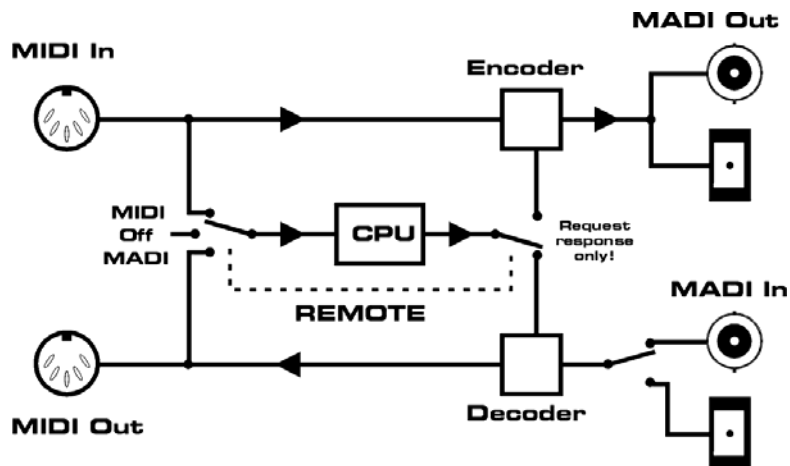

The MIDI input signal will never be transferred directly from MADI to MADI, no matter how the matrix router is set up. A MIDI cable connecting MIDI output and MIDI input of the ADI-648, will realize a direct pass-through of MIDI, from MADI input to MADI output.

### 10.2 Remote Controlling the ADI-648

The ADI-648 can be completely remote controlled via MIDI. The CPU shown above reacts on specific commands. Furthermore, upon request the CPU will report the complete device status. This includes all controls and LEDs on the front plate. Each ADI-648 can be programmed with its own ID, providing a separated remote control of multiple devices via a single MIDI channel. A description of the MIDI implementation is found in section 15.

The key REMOTE is used to select the source of the MIDI commands, and also the destination for the ADI-648's request replies. A push on REMOTE toggles between MIDI port, MADI port and Off. The latter is a safety function to prevent any setup-change by any MIDI signal. In the picture above, the MIDI commands reach the CPU via the MIDI input, and the CPU's feedback on commands is only available at the MIDI output.

To remote control an ADI-648 from a Hammerfall DSP via MADI, REMOTE has to be set to MADI. As can be seen in the block diagram on the next page, this setup provides a complete data path for MIDI in both directions.



### 10.3 Remote Control Software

The Windows software **MIDI Remote** can be downloaded for free from the RME website. It can use any existing MIDI port within the system to perform remote control and status requests of all ADI-648 via a simple mouse click. Most appealing is the combination with a HDSP MADI (PCI card), offering a direct control of the ADI-648 via MADI. The remote control software then uses a virtual MIDI port of the card (port 3), which directly sends and receives MIDI data via MADI.

The block diagram shows the signal flow in a MADI remote controlled system. MIDI commands from a software on PC or Mac travel via MADI to the MIDI Out of the ADI-648. At the same time they reach the 648's CPU. The MIDI signals of external devices travel via MIDI In and MADI Out back to the software, together with the request responses of the CPU.

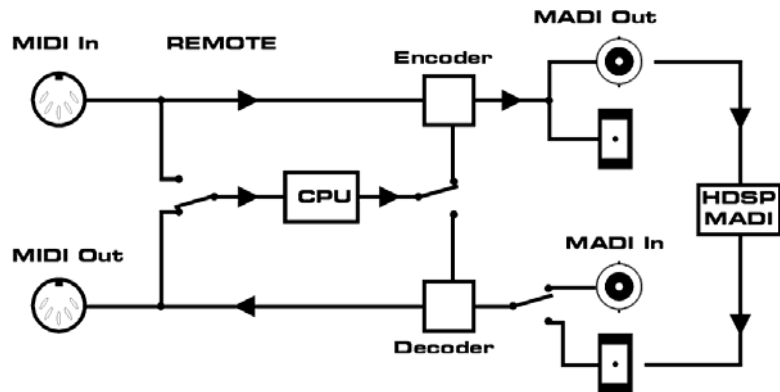

Software download adress: <http://www.rme-audio.com/download/midiremote.zip>

**MIDI Remote's** user interface offers lots of advanced features for an easy and intuitive everyday usage. Two views are available: a front-panel style surface, and a full matrix display. The following screenshot shows the software in operation and in both views.

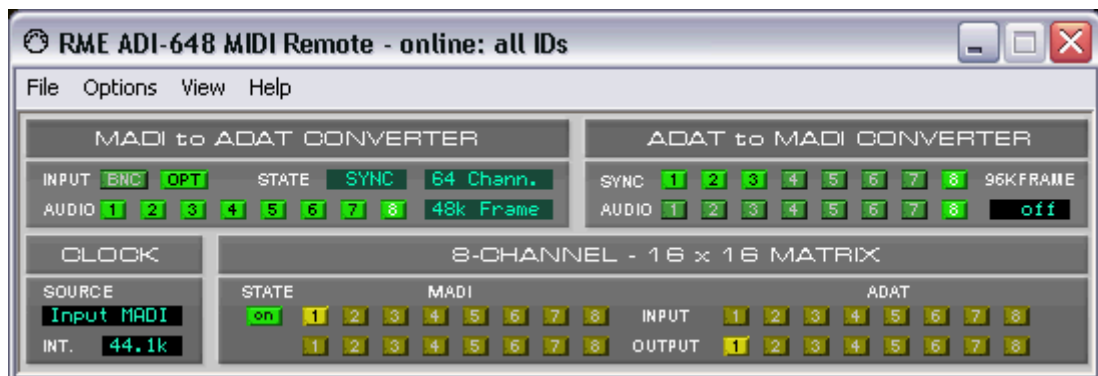

Software MIDI Remote in front panel view mode

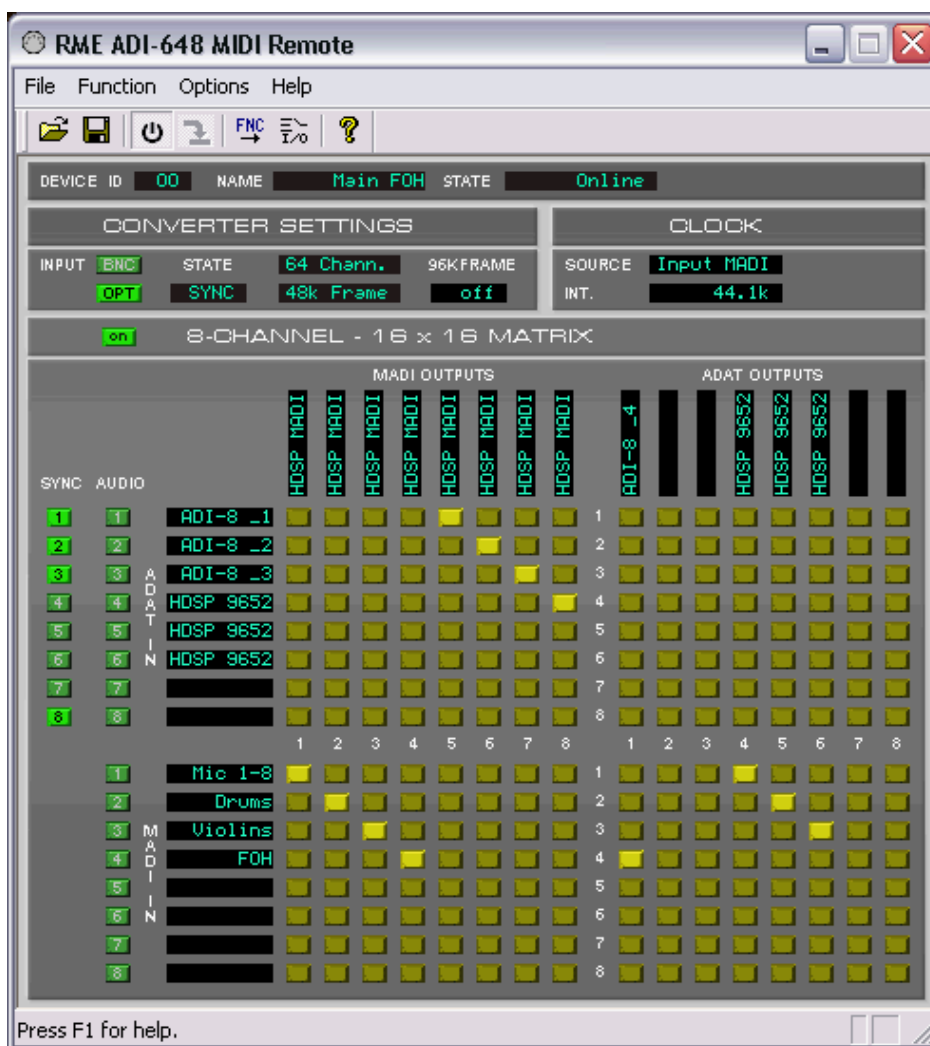

Software MIDI Remote in matrix view mode

## Brief description of Windows Software ADI-648 MIDI Remote

### File – Save Setup

All settings can be stored in a file, and reloaded at any time. This is especially useful to quickly load different routings, or to access different ADIs with different IDs.

### Options – Connect MIDI Ports

Start / Stop of the MIDI communication. The current state is displayed in the title bar, showing chosen ID, online / no response / offline.

### Options – MIDI Device Select

Opens a dialog to select the used MIDI input and output port.

### Options – Select Device ID

Opens a dialog box to select a device ID. Choosing 'All', the current device ID of the unit is ignored. The setting 'All' is not allowed when using more than one ADI-648.

### Options – Program Device ID

Opens a dialog to program a device ID into the ADI-648. Note: programming is fast and not confirmed. Attention: Programming is only possible when only one ADI-648 is connected via MIDI!

---

## 11. Special Modes

### 11.1 MAD I to MAD I Converter

MAD I has been used for quite some time now and therefore not all interfaces from different manufacturers are compatible with each other. An AMS Neve Logic DFC e. g. only accepts the 56 channel input format and when a 64 channel signal is applied, the whole input is muted. There exist lots of other but similar examples.

The ADI-648 can serve here as a perfect link, because its MAD I input can read any input format. The ADI-648's MAD I output can be set to 56 channel or 64 channel output mode by applying an ADAT signal to ADAT input 8 (see also chapter 7.2). After selecting 96K FRAME there are also 28 or 32 channels in a 96k Frame mode. With this option, the ADI-648 can translate a double wire MAD I signal (2 single speed channels contain one double speed channel's data) into a single wire double speed signal (1 channel contains 1 channel's data at double sample rate), or vice-versa.

Thanks to an integrated matrix router, no further cabling has to be arranged for (except for activating or deactivating of the 64 channel mode), since all MAD I input signals can be sent to the MAD I output directly via the router.

In short: the ADI-648 makes all MAD I interfaces existing at the moment compatible to each other in the easiest way.

### 11.2 ADAT Patchbay and Splitter

The integrated Matrix Router makes the ADI-648 also an interesting 8 port ADAT patchbay. No matter if different devices are to be connected with each other, or one ADAT signal has to be sent to multiple ADAT receivers, the ADI-648 can achieve this by simply pushing a button.

When the MAD I input and output are connected directly (loopback), the user can easily switch between a 1:1 connection and a freely defined router/splitter setting.

### 11.3 MAD I Coaxial / Optical Converter

The integrated Matrix Router allows to send the MAD I signals from the MAD I input directly to the MAD I output. As the ADI-648 supports both coaxial and optical format, it can be used as either coaxial to optical or optical to coaxial format converter. Thanks to a completely newly generated signal, jitter suppression by SteadyClock, and a reclocking of the MAD I output signal, the ADI-648 truly represents a hi-end format converter.

For such a simple application, the ADI-648 seems to be highly over-qualified. But seeing the very high prices (but not better quality) of dedicated format converters, we could not resist to add an explicite note on this ADI-648's capability.

### 11.4 MAD I Merger

Another very interesting application, else only possible by using very special and expensive devices, becomes reality when using more than one ADI-648: combining the audio channels of multiple MAD I sources into one single MAD I wire. The need for this application arises quite often, because many devices don't make use of the full channel count. Often only 32 or 40 channels are used. A HDSP MAD I card allows to record 64 channels simultaneously into a computer. To also use the remaining channels, further channels have to be added to the original MAD I signal. Two examples will show how the ADI-648 can handle this task with ease.

**Example 1:** A mixing desk sends 48 channels via MADI. 16 more channels from two RME OctaMic-D (8-channel microphone preamps with ADAT output) shall be recorded by a HDSP MADI into a computer. This application requires only one ADI-648, which has to be inserted into the MADI line. The Routing Matrix is used to loop channels 1 to 48 from MADI input to MADI output (groups 1 to 6). The two OctaMic-D will be connected to the ADAT inputs 7 and 8, which not only guarantee best overview, but also automatically activate the 64-channel mode. The Routing Matrix is now set up to send the ADAT input channels 49 to 64 (group 7 and 8) to channels 49 to 64 (group 7 and 8) of the MADI output. Now the ADI-648's MADI output signal includes both the original MADI input channels 1 to 48, and the audio signals of both OctaMics (on channels 49 to 64).

**Example 2:** The signals of two MADI devices shall be united to a single MADI stream. This can be handy, because it requires only one MADI cable for transmission. It can also be a requirement, because the receiving device may have only one input...

The number of ADI-648s necessary is identical to the number of MADI signal sources, so it's two for this example. The first ADI-648 serves as MADI to ADAT converter. Its ADAT outputs are connected with the ADAT inputs of the second ADI-648. The second ADI-648 is used as described in example 1, sending the MADI input signal directly to the MADI output. At the same time, the unit fills the unused MADI channels at its MADI output with the audio signals from the ADAT inputs.

The block diagram shows cabling and signal flow of such an application.

At the bottom, the setting of the second unit's Matrix Router is shown.

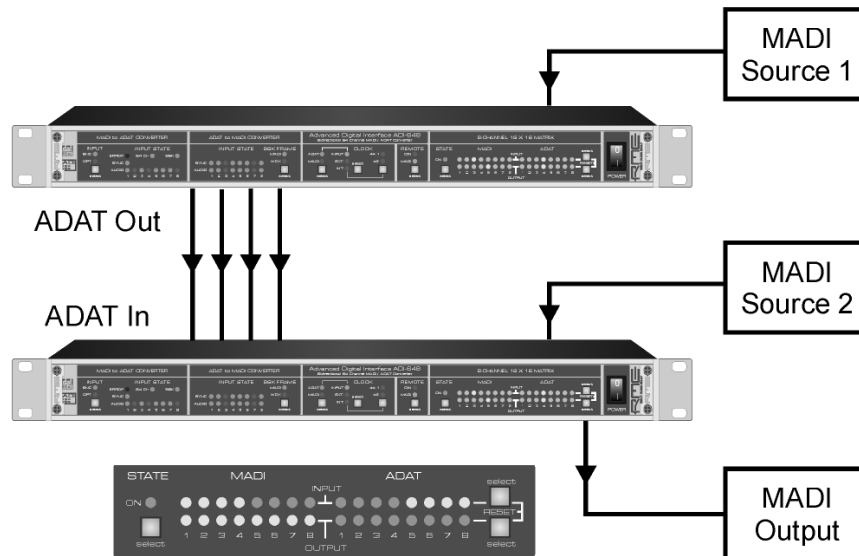

## 11.5 MADInet

MADI is much more flexible and powerful as commonly known. To better make clear what MADI really is – a kind of audio network – we introduced the term **MADInet**. The main point to know is that the MADI input signal is completely rebuilt before it is sent to the MADI output. A clock with active jitter suppression (like SteadyClock) provided, numerous ADI-648 can be daisy chained. The input signal can be passed on in different ways using the matrix router. And when build as as ring loop, audio can even be sent back from all ADI-648 to the first device. The specified length of BNC cable connections is multiplied by the number of used ADI-648, as each device resends the MADI signal as a newly generated original.

A real world example: Imagine a theme park, where different audio is needed at 20 places far away from each other. The audio material is send from a computer, playing back 20 different stereo tracks via a HDSP MADI. The card is connected via BNC to the first ADI-648. This one (like all others) is set up to pass all incoming audio 1:1 to its MADI output, so that the audio is sent directly to the next ADI-648. At the same time the audio is available at each unit using the ADAT optical outputs. The distance between the units is more than 50 meters. The last ADI-648 is connected with the HDSP MADI again, as each ADI-648 can also be used to insert signals into the loop (for example surveillance microphones). MIDI transmission included. Fascinating...

---

## 12. Technical Background

### 12.1 DS - Double Speed

When activating the 96k FRAME, the MADi output of the ADI-648 operates at double sample rate. The internal clock 44.1 kHz turns to 88.2 kHz, 48 kHz to 96 kHz. The internal resolution is still 24 bit.

Sample rates above 48 kHz were not always taken for granted, and are still not widely used because of the CD format (44.1 kHz) dominating everything. Before 1998 there were no receiver/transmitter circuits available that could receive or transmit more than 48 kHz. Therefore a work-around was used: instead of two channels, one AES line only carries one channel, of which the odd and even samples are being distributed to the former left and right channels. By this, you get the double amount of data, i. e. also double sample rate. Of course in order to transmit a stereo signal two AES/EBU ports are necessary then.

This transmission mode is being called *Double Wire* in the professional studio world, and is also known as *S/MUX* in connection with the ADAT format.

Not before February 1998, Crystal shipped the first 'single wire' receiver/transmitters that could also work with double sample rate. It was then possible to transmit two channels of 96 kHz data via one AES/EBU port.

But *Double Wire* is still far from being dead. On one hand, there are still many devices which can't handle more than 48 kHz, e. g. digital tape recorders. But also other common interfaces like ADAT or TDIF are still using this technique.

Because the ADAT interface does not allow for sampling frequencies above 48 kHz (a limitation of the interface hardware), the ADI-648 automatically uses the described *Sample Split* method in DS mode. One channel's data is distributed to two channels according to the following table:

Original	1	2	3	4	5	6	7	8
DS Signal	1/2	3/4	5/6	7/8	1/2	3/4	5/6	7/8
Port	1	1	1	1	2	2	2	2

As the transmission of double rate signals is done at standard sample rate (Single Speed) the word clock output still delivers 44.1 kHz or 48 kHz.

 *Nearly all devices with ADAT and TDIF ports generate a Single Speed word clock, because their ADAT and TDIF interfaces work in the same mode. At 96 kHz sample rate, the used word clock will be no higher than 48 kHz.*

Therefore the wordclock output of the ADI-648 also will be no higher than 48 kHz. In case a true Double Speed word clock is needed (88.2 or 96 kHz), press the key 96k FRAME several times, until the LED WCK is lit.

### 12.2 QS – Quad Speed

Due to the small number of available devices that use sample rates up to 192 kHz, but even more due to a missing real world application (CD...), Quad Speed has had no broad success so far. An implementation of the ADAT format as double S/MUX (S/MUX4) results in only two channels per optical output. Therefore in Quad Speed mode the ADI-648 is limited to 2 channels at the ADAT outputs. As MADi also uses the Quad Wire method at Quad Speed, only 16 channels are available instead of 64.

---

## 12.3 MADl Basics

MADl, the serial **M**ultichannel **A**udio **D**igital **I**nterface, has been defined already in 1989 as an extension of the existing AES3 standard following several manufacturers' wish. The format also known as AES/EBU, a balanced bi-phase signal, is limited to two channels. Simply put, MADl contains 28 of those AES/EBU signals in serial, i. e. after one another, and the sample rate can still even vary by +/-12.5%. The limit which cannot be exceeded is a data rate of 100Mbit/s.

Because an exact sampling frequency is used in most cases, the 64 channel mode was introduced officially in 2001. It allows for a maximum sample rate of 48 kHz + ca. 1%, corresponding to 32 channels at 96 kHz, without exceeding the maximum data rate of 100 Mbit/s. The effective data rate of the port is 125 Mbit/s due to additional coding.

Older devices understand and generate only the 56 channel format. Newer devices often work in the 64 channel format, but offer still no more than 56 audio channels. The rest is being eaten up by control commands for mixer settings etc.. The ADI-648 and the HDSP MADl show that this can be done in a much better way, with an invisible transmission of 16 MIDI channels and the MADl signal still being 100% compatible.

For the transmission of the MADl signal, proved methods known from network technology were applied. Most people know unbalanced (coaxial) cables with 75 Ohms BNC plugs, they are not expensive and easy to get. The optical interface is much more interesting due to its complete galvanic separation, but for many users it is a mystery, because very few have ever dealt with huge cabinets full of professional network technology. Therefore here are some explanations regarding 'MADl optical'.

- The cables used are standard in computer network technology. They are thus not at all expensive, but unfortunately not available in every computer store.
- The cables have an internal fibre of only 50 or 62.5 µm diameter and a coating of 125 µm. They are called network cables 62.5/125 or 50/125, the former mostly being blue and the latter mostly being orange. Although in many cases not clearly labeled, these are always (!) glass fibre cables. Plastic fibre cables (POF, plastic optical fibre) can not be manufactured in such small diameters.
- The plugs used are also an industry standard and called SC. Please don't mix them up with ST connectors, which look similar to BNC connectors and are being screwed. Plugs used in the past (MIC/R) were unnecessarily big and are not being used any longer.
- The cables are available as a duplex variant (2 cables being glued together) or as a simplex variant (1 cable). The ADI-648's opto module supports both variants.
- The transmission uses the multimode technique which supports cable lengths of up to almost 2 km. Single mode allows for much longer distances, but it uses a completely different fibre (8 µm). By the way, due to the wave-length of the light being used (1300 nm), the optical signal is invisible to the human eye.

## 12.4 SteadyClock

The SteadyClock technology of the ADI-648 guarantees an excellent performance in all clock modes. Its highly efficient jitter suppression refreshes and cleans up any clock signal, and provides it as reference clock at the word clock output.

Usually a clock section consists of an analog PLL for external synchronization and several quartz oscillators for internal synchronisation. SteadyClock requires only one quartz, using a frequency not equalling digital audio. Latest circuit designs like hi-speed digital synthesizer, digital PLL, 200 MHz sample rate and analog filtering allow RME to realize a completely newly developed clock technology, right within the FPGA at lowest costs. The clock's performance exceeds even professional expectations. Despite its remarkable features, SteadyClock reacts quite fast compared to other techniques. It locks in fractions of a second to the input signal, follows even extreme varipitch changes with phase accuracy, and locks directly within a range of 25 kHz up to 100 kHz.

SteadyClock has originally been developed to gain a stable and clean clock from the heavily jittery MADI data signal. The embedded MADI clock suffers from about 80 ns jitter, caused by the time resolution of 125 MHz within the format. Common jitter values for other devices are 5 ns, while a very good clock will have less than 2 ns.

The picture to the right shows the MADI input signal with 80 ns of jitter (top graph, yellow). Thanks to SteadyClock this signal turns into a clock with less than 2 ns jitter (lower graph, blue).

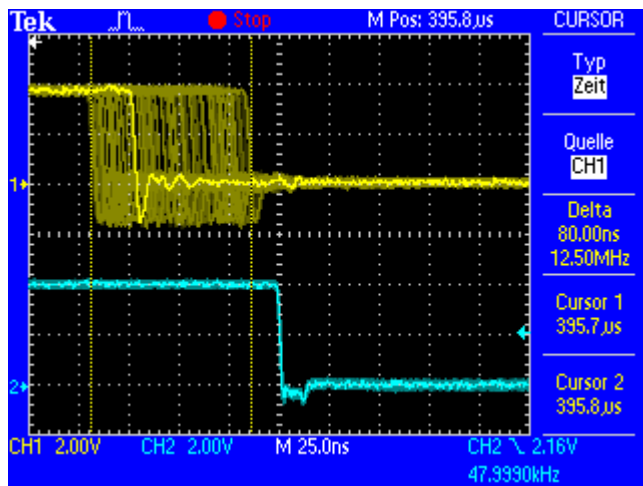

Using the other inputs sources of the ADI-648, word clock and ADAT, you'll most probably never experience such high jitter values. But SteadyClock is not only ready for them, it would handle them just on the fly.

The screenshot to the right shows an extremely jittery word clock signal of about 50 ns jitter (top graph, yellow). Again SteadyClock provides an extreme clean-up. The filtered clock shows less than 2 ns jitter (lower graph, blue).

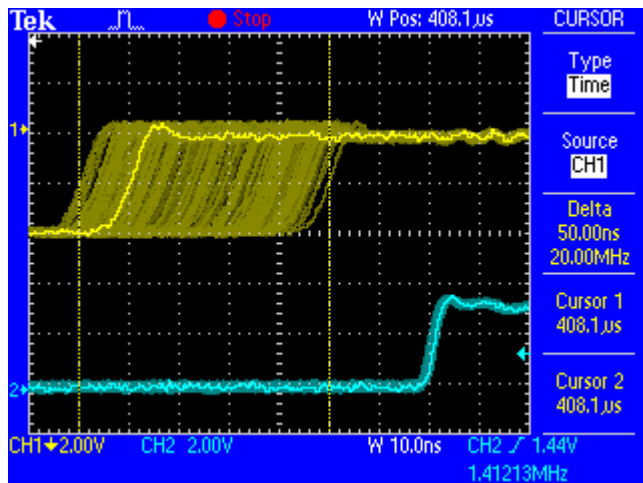

The cleaned and jitter-freed signal can be used as reference clock for any application, without any problem. The signal processed by SteadyClock is of course not only used internally, but also available at the ADI-648's word clock output. It is also used to clock the digital outputs MADI and ADAT.

# 13. Controls and Connectors

## Front Left Part

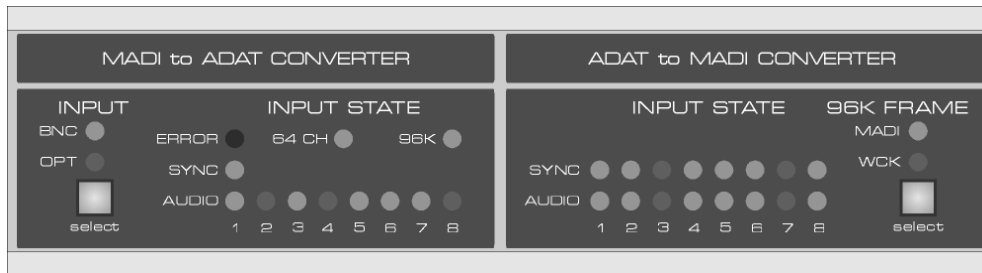

Signal source  
BNC  
Optisch

Status display  
Error  
Sync  
Audio

Status display  
Input Sync  
Audio

Status MADI Output  
96k Frame  
DS word clock

## Front Right Part

### Clock Section

### Matrix Router

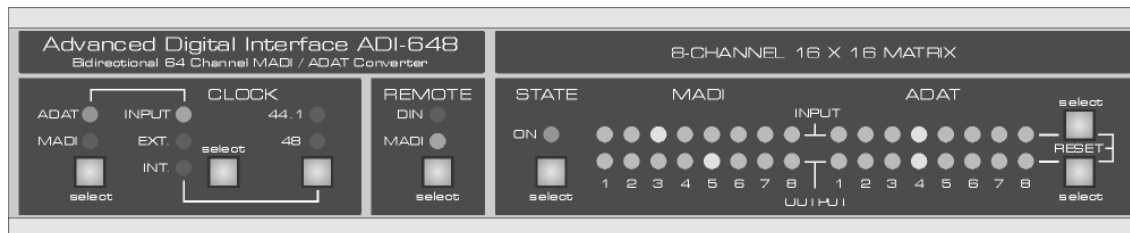

Clock Source  
ADAT  
MADI

Internal Clock  
44.1 / 48 kHz  
96k Frame  
88.2 / 96 kHz

Matrix Router  
On/Off

Input/Output  
Select  
Reset

Clock Source  
Input  
Word  
Internal

Remote control via  
DIN  
MIDI

## Rear

### Power

### MADI I/O

### ADAT I/O

### Wordclock I/O



### MIDI I/O



## 14. Block Diagram (excluding MIDI)

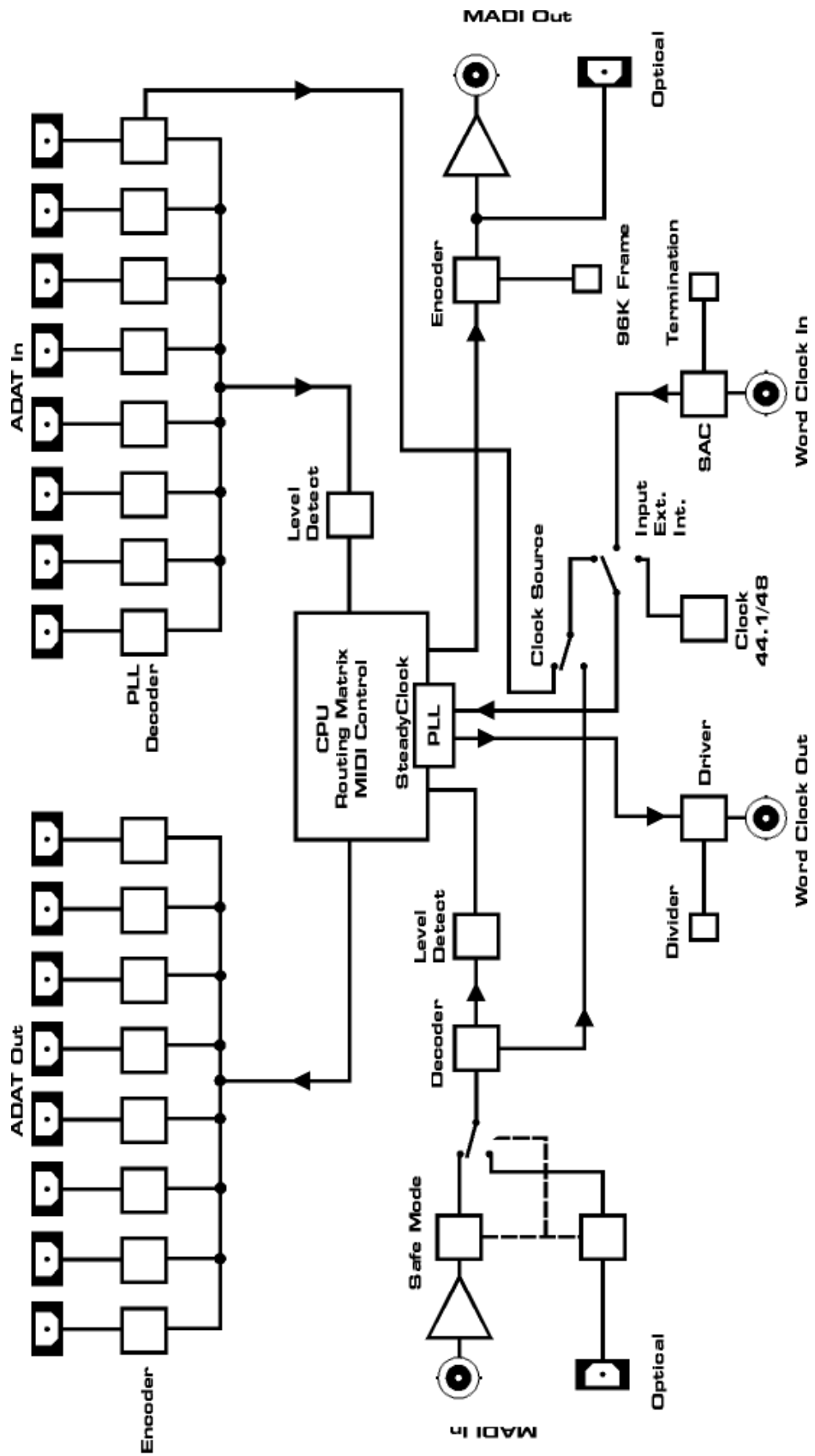

---

## 15. MIDI Implementation Chart ADI-648

### 15.1 Basic SysEx Format

<u>Value</u>	<u>Name</u>
F0h	SysEx header
00h 20h 0Dh	MIDITEMP manufacturer ID
64h	Model ID (ADI-648)
00h..7Eh, 7Fh	Device ID. 7Fh = broadcast (all IDs)
mm	Message type
nn	Parameter number (see table 1)
oo	Databyte
F7h	EOX

### 15.2 Message Types

<u>Value</u>	<u>Name</u>
10h	Request value
20h	Set value
30h	Value response

#### Request Value

Format: F0 00 20 0D 64 (dev ID) 10 F7

This string triggers a complete dump of all value response data bytes.

#### Value Response

After being triggered by receiving a request value command, device sends a string of all value response data bytes. Message type is set to 30h.

#### Set Value

Sets any number of parameters.  
nn / oo can be repeated freely.

### 15.3 MADi Input State – Redundancy Mode

The MADi input can be BNC or optical. When the ADI-648 enters Redundancy mode, it uses the other input, although not chosen and signalled by the MADi input select byte. See below table.

MADi Input Select	MADi Input State	Actual input in use
0 = BNC	0 = normal operation	BNC
1 = Optical	0 = normal operation	Optical
0 = BNC	1 = Redundancy mode	Optical
1 = Optical	1 = Redundancy mode	BNC

**Table 1**

No.	Name	Request Value	Set Value	Value Response	Databytes
00h	MADI input select	x	x	x	1 Byte, 0 = BNC, 1 = optical
01h	MADI input state	x		x	1 Byte, 0 = normal operation, 1 = Redundancy mode
02h	MADI sync state	x		x	1 Byte, 0 = error, 1 = lock, 2 = sync
03h	MADI audio state	x		x	1 Byte, see <i>table 2</i>
04h	MADI audio state	x		x	1 Byte, see <i>table 2</i>
05h	MADI input format display	x		x	1 Byte, bit 0: 0 = 56ch / 1 = 64ch, bit 1: 0 = 48k frame, 1 = 96k frame
06h	WCK input state	x		x	1 Byte, 0 = no lock, 1 = lock
10h	ADAT in 1 and 2 state	x		x	1 Byte, see <i>table 3</i>
11h	ADAT in 3 and 4 state	x		x	1 Byte, see <i>table 3</i>
12h	ADAT in 5 and 6 state	x		x	1 Byte, see <i>table 3</i>
13h	ADAT in 7 and 8 state	x		x	1 Byte, see <i>table 3</i>
14h	ADAT audio state	x		x	1 Byte, see <i>table 2</i>
15h	ADAT audio state	x		x	1 Byte, see <i>table 2</i>
16h	96k frame	x	x	x	1 Byte, bit 0: MADI on, bit 1: WCK on
20h	clock source	x	x	x	1 Byte, 1 = INT 44, 2 = INT 48, 3 = WCK, 4 = MADI, 5 = ADAT
30h	matrix enable	x	x	x	1 Byte, 0 = disable, 1 = enable
31h	matrix reset		x		1 Byte, 1 = reset
40h	matrix output 1	x	x	x	1 Byte, 0..15 = input no., 16 = no input
41h	matrix output 2	x	x	x	1 Byte, 0..15 = input no., 16 = no input
42h	matrix output 3	x	x	x	1 Byte, 0..15 = input no., 16 = no input
43h	matrix output 4	x	x	x	1 Byte, 0..15 = input no., 16 = no input
44h	matrix output 5	x	x	x	1 Byte, 0..15 = input no., 16 = no input
45h	matrix output 6	x	x	x	1 Byte, 0..15 = input no., 16 = no input
46h	matrix output 7	x	x	x	1 Byte, 0..15 = input no., 16 = no input
47h	matrix output 8	x	x	x	1 Byte, 0..15 = input no., 16 = no input
48h	matrix output 9	x	x	x	1 Byte, 0..15 = input no., 16 = no input
49h	matrix output 10	x	x	x	1 Byte, 0..15 = input no., 16 = no input
4Ah	matrix output 11	x	x	x	1 Byte, 0..15 = input no., 16 = no input
4Bh	matrix output 12	x	x	x	1 Byte, 0..15 = input no., 16 = no input
4Ch	matrix output 13	x	x	x	1 Byte, 0..15 = input no., 16 = no input
4Dh	matrix output 14	x	x	x	1 Byte, 0..15 = input no., 16 = no input
4Eh	matrix output 15	x	x	x	1 Byte, 0..15 = input no., 16 = no input
4Fh	matrix output 16	x	x	x	1 Byte, 0..15 = input no., 16 = no input
60h	device ID	x	x	x	1 Byte (00h..7Eh, 7Fh = broadcast)

---

**Table 2**

1st Byte bit 0	input 1 audio indication
1st Byte bit 1	input 2 audio indication
1st Byte bit 2	input 3 audio indication
1st Byte bit 3	input 4 audio indication
2nd Byte bit 0	input 5 audio indication
2nd Byte bit 1	input 6 audio indication
2nd Byte bit 2	input 7 audio indication
2nd Byte bit 3	input 8 audio indication

**Table 3**

bits 0..2	ADAT in 1 / 3 / 5 / 7, 0 = error, 1 = lock, 2 = sync
bits 4..6	ADAT in 2 / 4 / 6 / 8, 0 = error, 1 = lock, 2 = sync

---

## 16. Warranty

Each individual ADI-648 undergoes comprehensive quality control and a complete test at IMM before shipping. The usage of high grade components allow us to offer a full two year warranty. We accept a copy of the sales receipt as valid warranty legitimation.

If you suspect that your product is faulty, please contact your local retailer. The warranty does not cover damage caused by improper installation or maltreatment - replacement or repair in such cases can only be carried out at the owner's expense.

Synthax Audio AG does not accept claims for damages of any kind, especially consequential damage. Liability is limited to the value of the ADI-648. The general terms of business drawn up by Synthax Audio AG apply at all times.

## 17. Appendix

RME news and further information can be found on our website:

<http://www.rme-audio.com>

Distributor: Synthax Audio AG, Am Pfanderling 62, D-85778 Haimhausen, Tel.: (49) 08133 / 91810

Manufacturer:  
IMM Elektronik GmbH, Leipziger Strasse 32, D-09648 Mittweida

### Trademarks

All trademarks and registered trademarks belong to their respective owners. RME, SyncAlign, Hammerfall and SyncCheck are registered trademarks of RME Intelligent Audio Solutions. Intelligent Clock Control (ICC), SteadyClock and Fireface are trademarks of RME Intelligent Audio Solutions. Alesis and ADAT are registered trademarks of Alesis Corp. ADAT optical is a trademark of Alesis Corp. S/MUX is copyright Sonorus.

Copyright © Matthias Carstens, 1/2007. Version 2.3

All entries in this User's Guide have been thoroughly checked, however no guarantee for correctness can be given. RME cannot be held responsible for any misleading or incorrect information provided throughout this manual. Lending or copying any part or the complete manual or its contents as well as the software belonging to it is only possible with the written permission from RME. RME reserves the right to change specifications at any time without notice.

---

## CE / FCC Compliance

### CE

This device has been tested and found to comply with the limits of the European Council Directive on the approximation of the laws of the member states relating to electromagnetic compatibility according to RL89/336/EWG and RL73/23/EWG.

### FCC Compliance Statement

Certified to comply with the limits for a Class B computing device according to subpart J or part 15 of FCC rules. See instructions if interference to radio reception is suspected.

### FCC Warning

This equipment has been tested and found to comply with the limits for a Class B digital device, pursuant to part 15 of the FCC rules. These limits are designed to provide reasonable protection against harmful interference in a residential installation.

This device complies with part 15 of FCC rules. Operation is subject to the following two conditions:

1. This device may not cause harmful interference
2. This device must accept any interference received, including interference that may cause undesired operation.

However, there is no guarantee that interference will not occur in a particular installation. If this equipment does cause harmful interference to radio or television reception, which can be determined by turning the equipment off and on, the user is encouraged to try to correct the interference by one or more of the following measures:

- Reorient or relocate the receiving antenna
- Increase the separation between the equipment and receiver
- Connect the equipment into an outlet on a circuit different from that to which the receiver is connected
- Consult the dealer or an experienced radio/TV technician for help.

In order for an installation of this product to maintain compliance with the limits for a Class B device, shielded cables must be used for the connection of any devices external to this product.

### Note on Disposal

According to the guide line RL2002/96/EG (WEEE – Directive on Waste Electrical and Electronic Equipment), valid for all European countries, this product has to be recycled at the end of its lifetime.

In case a disposal of electronic waste is not possible, the recycling can also be done by IMM Elektronik GmbH, the manufacturer of the Micstasy.



For this the device has to be sent **free to the door** to:

IMM Elektronik GmbH  
Leipziger Straße 32  
D-09648 Mittweida  
Germany

Shipments not prepaid will be rejected and returned on the original sender's costs.